

F6350



CURRENT/ VOLTAGE AMPLIFIERS

Detailed testing of protective relays, protective schemes, and control systems are often performed using a closed loop real time system such as the one illustrated below.

This type of testing is similar to the conventional transient playback tests except that the simulation is live and interactive. The closed loop real time testing involves three basic components; the RTDS (Real Time Digital Simulator), the current/voltage amplifiers, and the device under test. As shown in Figure 1 below, the RTDS simulates the voltages and currents based on the results of a real time simulation that is conducted in the background. These low level voltage and current signals are passed on to the voltage/current amplifiers

TOGETHER WE POWER THE WORLD®

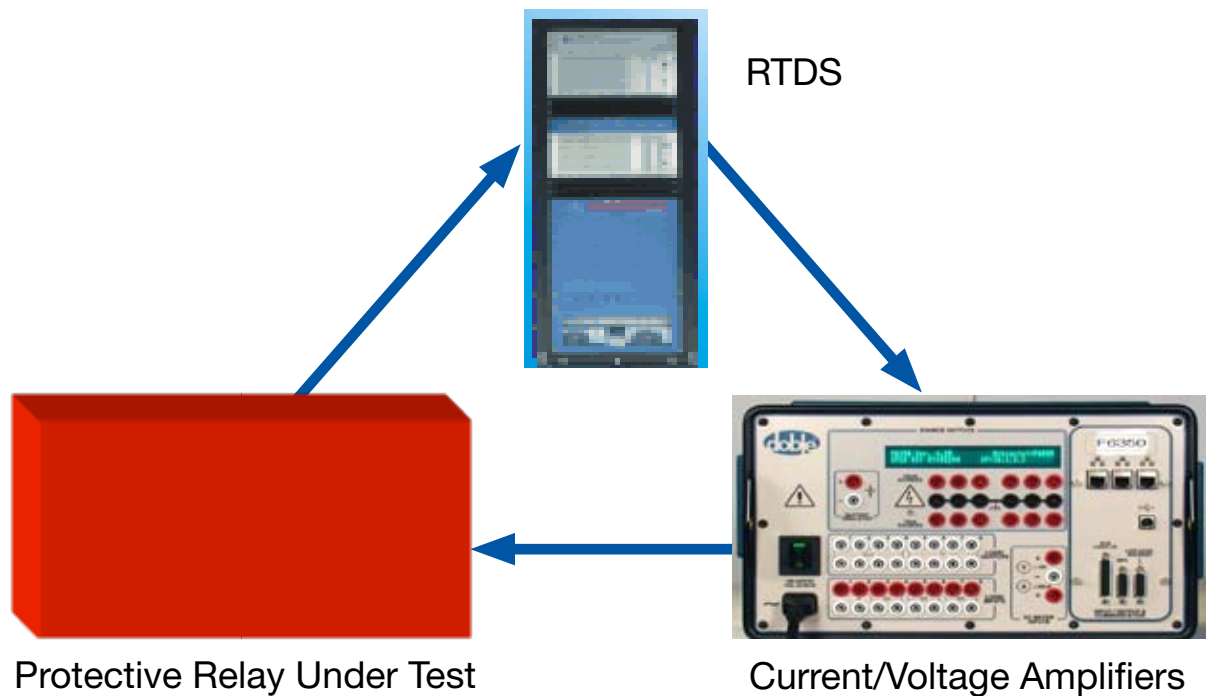

Figure 1: Closed Loop Real Time Testing

The amplifiers supply the appropriate signals (V and I) to the device under test. The response of relay elements to the voltages and currents is transmitted back to the RTDS via its logic inputs and outputs. Upon receipt of this updated information from the relay, the simulation is modified and revised low level current and voltages are transmitted back to the amplifier. This closed loop process continues until the simulation is terminated.

Doble's F6350 is used as current/voltage amplifier as shown above. It receives the low level signal from the RTDS and supplies the amplified signals to device under test.

The F6350 is designed to accept a range of low level signals and the output range is selected to conform linearly to the low level input signals.

The four low level signal limits are as follows:

A 6.7 V rms low level signal will produce a voltage equal to the high end of voltage range selected for the F6350. For example, if the output range is selected as 75V, 6.7V rms will correspond to 75V. Similarly if a range of 150V is selected, the 6.7V rms will generate an output of 150V. The three ranges of voltage outputs are 75V, 150V and 300V.

Similarly, the current channels are designed such that a 3.4V rms low level signal will correspond to the high end of the current range selected for the F6350

Also, the F6350 supports a transient current output. A low level signal of 6.8V rms corresponds to a transient current output of 1.5 times the normal current range for 1.5 seconds.

The fourth and the last output limit pertains to the low level current outputs from the convertible source (an option available in F6150). A 4.7 V rms signal from RTDS will result in 0.5A, 1A or 2A depending upon the range selected in the F6350 configuration software.

The selection of the ranges and the enabling of the amplifiers are performed via the F6350 software that is installed on the PC. This software is similar to the control panel software of the F6150.

Figure 2 shows a screen capture of this software.

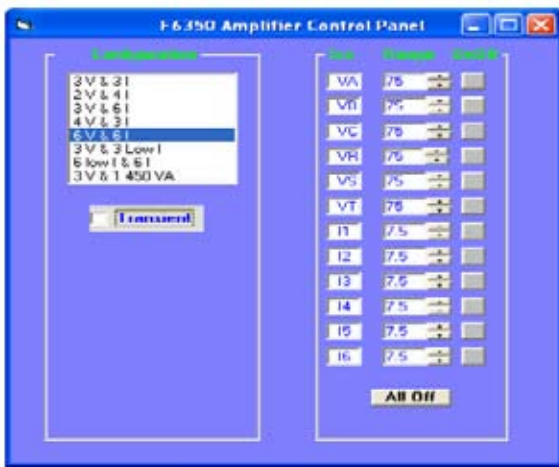

Figure 2: Configuration software for selecting voltage and current ranges

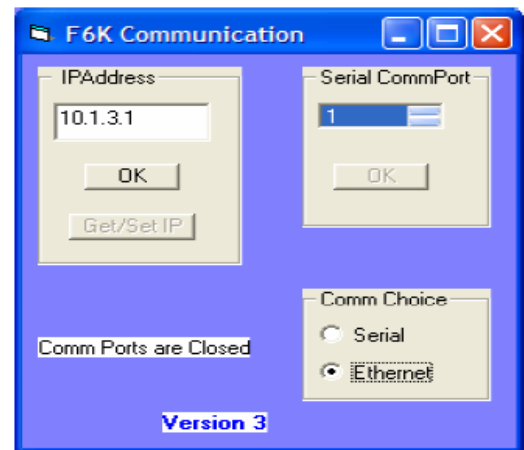

Figure 3: Configuration software for selecting communication option between software and the F6350

The communication between F6350 and the configuration software is user selectable as shown in Figure 3. This selection is done via the configuration software.

The connection diagram shown in Figure 4 illustrates the test set up using one F6350.

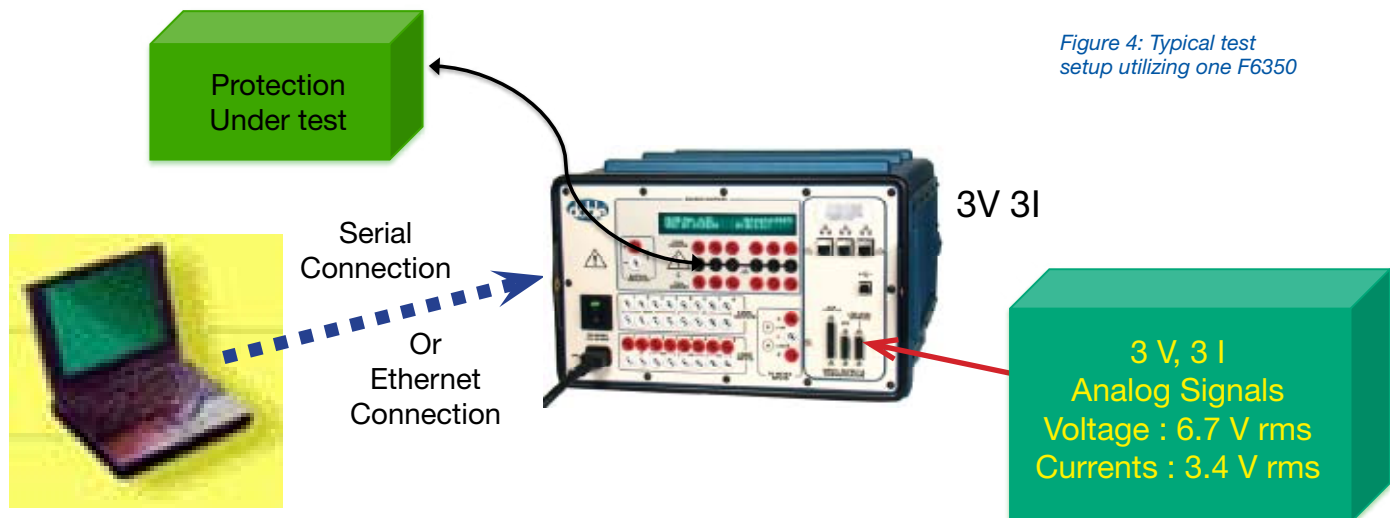

Figure 4: Typical test setup utilizing one F6350

As shown in Figure 4, the communication between the configuration software and F6350 is via either serial or ethernet. The connection between the RTDS and the F6350 is via a special cable provided as part of the F6350 package. The port on the F6350 that accepts this special cable is the one labeled Low Level Sources

The application of F6350 is very flexible. It allows the use of several F6350 to accommodate the need for additional voltage and current sources. Figure 5 shows one such application.

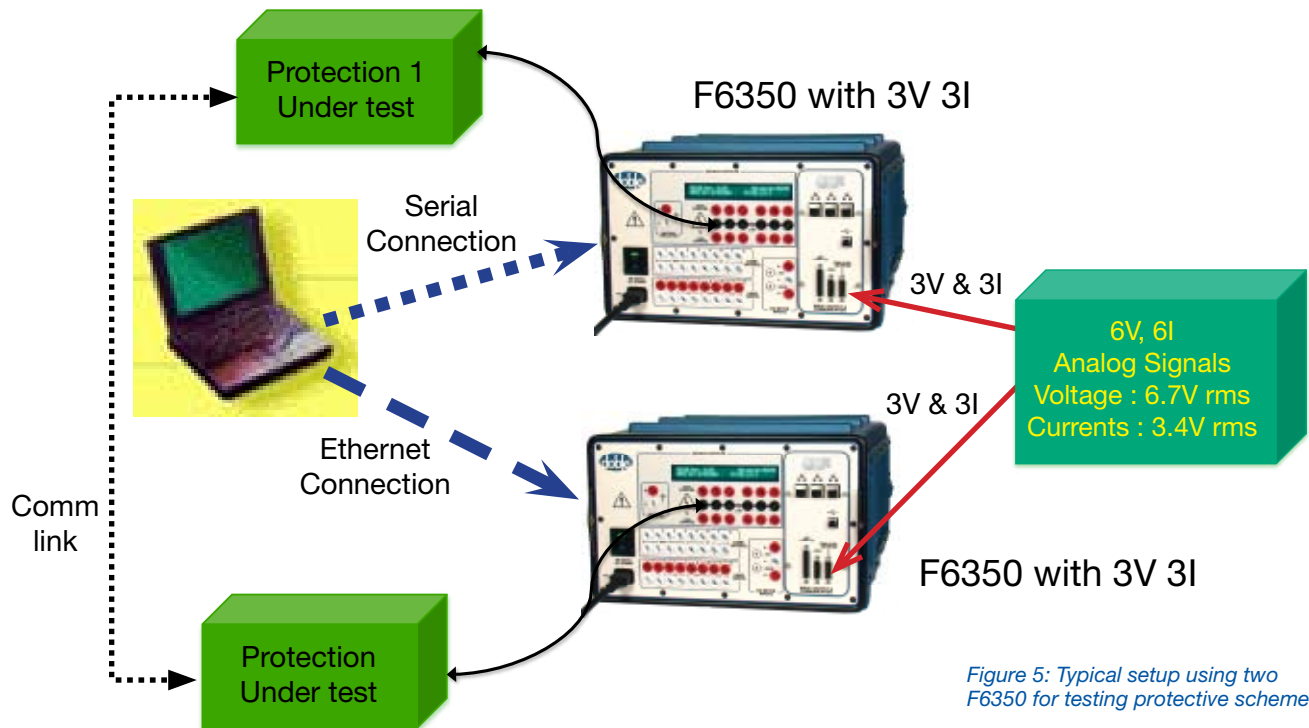

Figure 5: Typical setup using two F6350 for testing protective schemes

The test setup (shown in Figure 5) is very helpful in testing various protective schemes where there is a need for several current and voltage sources.

If there is a need for additional current sources without the need for additional voltage sources, the application of F6300 is a good way of accomplishing the test requirements (shown in Figure 6 below). The application of F6350 or F6300 is very flexible. It allows the use of several F6350/ F6300 to accommodate the need for additional voltage and current sources

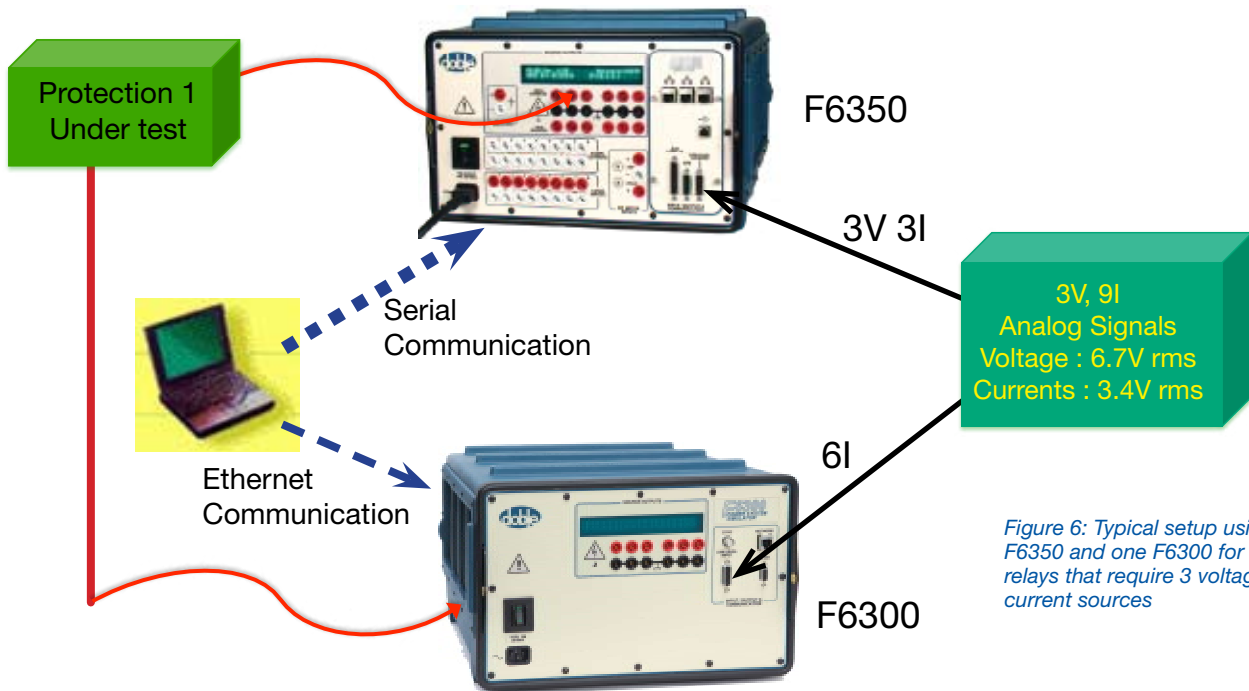

Figure 6: Typical setup using one F6350 and one F6300 for testing relays that require 3 voltage and 9 current sources

The source combinations listed above are just a sample. For more combinations, please refer to the Doble document titled Real Time Simulations using F6000 instruments.

Ordering Information:

There are two options available for ordering the F6350:

If you need a dedicated F6350, you can order such a unit by selecting this option. You may want to do this if you plan to either use the amplifier on a regular basis or you do not have a F6150 (Doble Power System Simulator).

The second option is for clients who have a F6150 and would like to use the F6150 as either an amplifier or as a test set. In such a case the F6150 can be converted to a F6350 and vice versa whenever a need arose for using voltage and current amplifiers. If this option is exercised, the conversion kit is all you need to purchase from Doble. The conversion kit contains the following:

- A cable for connecting the F6350 to the RTDS
- An analog I/O board
- A CD containing the configuration and the required firmware for F6350.

Please refer to Doble Document titled Real Time Power System Simulation Using F6000 instruments for more detailed description of the application, cable details along with the pin designations for the low level cable that connects the RTDS to the F6350.

If you select the option of purchasing the conversion kit only, you will need to know the process of performing the conversion. The details for performing the conversion are listed in the Doble document titled Real Time Power System Simulation using F6000 instruments.

Note:

The conversion process is simple and takes less than 15 minutes.

The process for converting the F6350 to F6150 is also as simple as the one for converting F6150 to F6350.

For more information, contact
fserieshelp@doble.com



Doble Engineering Company

85 Walnut Street
Watertown, MA 02472 USA
tel +1 617 926 4900
fax +1 617 926 0528