



**AC DIELECTRIC TEST SET  
600P SERIES**

**Version 2.2**

**Model Number 640-0.4P**

**(Optimized for Vacuum Bottle Testing)**

# TABLE OF CONTENTS

	<u>Section Number</u>
DANGER / GENERAL SAFETY PRECAUTIONS	
TECHNICAL SPECIFICATIONS	1
CONTROLS AND INDICATORS	2
ELECTRICAL SET-UP / GROUND – GUARD CONNECTIONS	3
OPERATING INSTRUCTIONS	4
CALIBRATION	5
TROUBLESHOOTING	6
STORAGE OF EQUIPMENT	7
CIRCUIT DIAGRAM SYMBOLS	8
ELECTRICAL DIAGRAMS	9
PARTS LIST	10
PARTS ORDERING INFORMATION	11
RECOMMENDED SPARE PARTS	12
RETURNED MATERIAL	13

**DANGER / WARNINGS**  
**WARNING !!**

**DANGER**

**Complete Grounding of this unit is necessary for the safe operation of this equipment. Disconnect inputs before ungrounding this equipment**

## GENERAL SAFETY PRECAUTIONS



# CAUTION

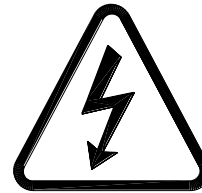

### HIGH VOLTAGE

**This equipment is capable of providing POTENTIALLY LETHAL VOLTAGES! Improper operation or test practices may result in injury or death to the operator or surrounding personnel.**

The operation of High Voltage test equipment should only be performed by personnel familiar with HIGH VOLTAGE testing and safety procedures. The operator of this equipment must be aware of all hazards associated with High Voltage testing. The operator is responsible for himself and others in close proximity of the testing area.

Some General Safety Practices for working with High Voltage Test Equipment have been listed below for your reference.

- Become familiar with your instrument before performing an actual test
- Know your work area, check that all circuits are de-energized and locked out.
- Never work alone; always work with another qualified worker.
- Mark off entire work area with barriers and warning tape.
- Make all personnel aware of your testing activities.
- Be aware of dangerous conditions that may arise from energizing a test specimen.
- Never modify test equipment, modifications to equipment could introduce an unknown hazard or hinder a designed-in safety feature.
- DO NOT operate damaged equipment. Remove power, and do not use the equipment until safe operation can be verified by service-trained personnel.

Phenix Technologies, Inc. assumes no liability for unsafe or improper use of test equipment.

## SECTION 1: TECHNICAL SPECIFICATIONS

### Input

120 volts, 60 Hz, single phase, 400 VA, 5 amperes  
or  
220 volts, 50 Hz, single phase, 400 VA, 3 amperes

### Output Rating

40 kilovolts, 10 milliamperes

### Duty Cycle

120 volt, 20 MINUTES ON / 30 MINUTES OFF at 10 mA  
220 volt, 15 MINUTES ON / 45 MINUTES OFF at 10 mA

### Type of Cooling

AN (Air Natural)

### Distortion

Less than 5 percent at full load

### Impedance

Less than 10 percent at rated current

### Operating Ambient Temperature

0-40 degrees Celsius

### Output Termination

HV Dome with output lead.

**NOTE: THE HV LEAD PROVIDED IS FOR EASE OF HANDLING ONLY. IT IS NOT INTENDED FOR USE WITH DIRECT CONTACT TO GROUND OR OTHER CONDUCTIVE SURFACES. THE LEAD MUST BE SUSPENDED IN AIR WITH ADEQUATE CLEARANCE FOR PROPER OPERATION.**

### Metering

**Output Voltmeter:** 3 ½ digit LCD, ±1% full scale accuracy. Range: 0-40 kV

**Output Currentmeter:** 3 ½ digit LCD, ±1% full scale accuracy. Range: 0-10 mA

### Sizes and Weights

19.5" (495 mm) H x 18.5" (464 mm) W x 10.75" (273 mm) D  
Weight: 56 pounds (25.4 kg)  
[For 220 - 250V add 3.5 lbs (1.6 kg)]

## SECTION 2: CONTROLS AND INDICATORS

Refer to corresponding numbers on Panel Diagram.

1. **Main Power Input Module.** Turns main power of unit on and off and provides input overload protection, **F1**.
2. **F2.** Provides protection for T1 regulator and high voltage module.
3. **Emergency Off.** Mushroom switch shuts off all unit functions when pressed down. If unit appears totally inoperative, with no lamps and no meter display, check first to see that this switch is pulled up in the On position.
4. **High Voltage On.** Momentary switch activates power to high voltage circuits when pre-required conditions are met.

### Conditions required for HV ON activation are:

- Power applied to unit and **Power Input Module switch** (1) turned on.
  - **Emergency off** switch must be pulled up. (3)
  - **External Interlock** circuit series loop must not be open if applicable. (Optional)
  - **Voltage Control** (6) must be at zero. (Zero Start)
  - Current Trip circuit must be reset if **Reset** lamp is illuminated (7).
5. **High Voltage Off.** Momentary switch turns high voltage off when activated.
  6. **Voltage Control.** Turn clockwise to raise output voltage. **High voltage cannot be activated if Voltage Control is not started at zero.**
  7. **Reset.** **Reset** lamp illuminates to show that current trip circuit has tripped. High voltage circuits are deactivated. Momentary **Reset** switch must be pressed to extinguish **Reset** lamp to allow high voltage to be reapplied after returning **Voltage Control** (6) to zero.
  8. **Current Trip Adjust.** Dial adjusts from 1 to 11 corresponding to 10% to 110% of rated output current (10mA). **Current Trip/Reset** lamp illuminates and high voltage turns off when output current exceeds setting, causing circuit to trip. Circuit also acts as short circuit and overload protection on high voltage output. To reactivate high voltage, **Voltage Control** (6) must be returned to zero and **Reset** switch (7) must be pressed to clear **Current Trip** circuit.
  9. **Currentmeter.** Displays output current of test set in milliamps, resolution to .01mA.
  10. **Voltmeter.** Displays output voltage of test set in kilovolts, resolution to .1 kilovolt.

## CONTROLS AND INDICATORS

11. **Ext. Intlk. – SX1.** (Optional) Provides for user connection of external interlock or auxiliary safety control device such as emergency off switch, gate switch, foot switch, dead man switch, etc. Included plug has shorting jumper installed to complete circuit. Jumper must be removed, and cable connected to user supplied device by user if desired to use this provision. Only non-energized switch or dry relay contact devices may be used. This is a series 120VAC circuit that must remain closed for high voltage to be activated.
12. **J1.** Provided interconnect cable is connected here and to the same designation connector on the high voltage unit.
13. **Line Cord.** Supplies input power to unit.

### Control Panel Layout







## SECTION 3: ELECTRICAL SET-UP

**WARNING: Be sure the Main Power Plug of the control unit is unplugged before proceeding. This unit should only be operated by personnel knowledgeable in High Voltage testing and safety procedures. Improper or careless operation of unit can result in serious injury or death.**

1. Locate the desired location for the test set. Prepare the main power input cable for plugging in to the proper facility power (i.e., 120 volts AC or 220 volts AC). Leave plug unconnected at this time. Make sure power input module switch is off.
2. Connect interconnect cable between controls and high voltage unit.
3. External Interlock (Optional)

If an external interlock is not to be used, plug the connector as supplied into the socket on the control panel marked "**EXT INTLK**", "**SX1**", if not already in place.

If an external interlock is to be used, remove the jumper on the plug of the "**EXT INTLK**" circuit and connect the external security circuit at these points. (NOTE: The external interlock circuit must consist of a closed loop of dead contacts. When the control power is on, the external circuit will be energized with 120 volts AC.)

### High Voltage Connection

**WARNING: Power Input Module Switch on the front panel must be in the OFF position before proceeding. Test specimen must be de-energized and discharged.**

1. Connect the ground post located on the H.V. Transformer to facility ground with supplied ground cable or low inductance cable or braid. If low potential side of test specimen is grounded, Ground post may be connected to this point.
2. Connect the low potential side of test specimen to the Return terminal. (Refer to Ground-Guard-Return Connections for other connection options).  
**Note:** The Jumper Clip on the binding posts on the HV unit must always be connected, either between Ground ("GND") and Return ("RTN") posts or between Ground and Guard ("GRD") posts, as appropriate. Do Not operate unit without the Jumper Clip firmly connected.
3. Connect the high potential side of the test specimen to the HV output dome on the unit. **If using the supplied high voltage cable, keep the cable suspended away from all ground or non-related potential points.**  
**Note:** Output cable supplied is not rated for full unit voltage and will exhibit partial discharge if too near ground.
4. Check that the **power input module switch** is turned off and connect input main power cable to a suitable grounded receptacle

Brief connection diagram on next page.

# ELECTRICAL SETUP

## HV CONNECTIONS AND GROUNDING

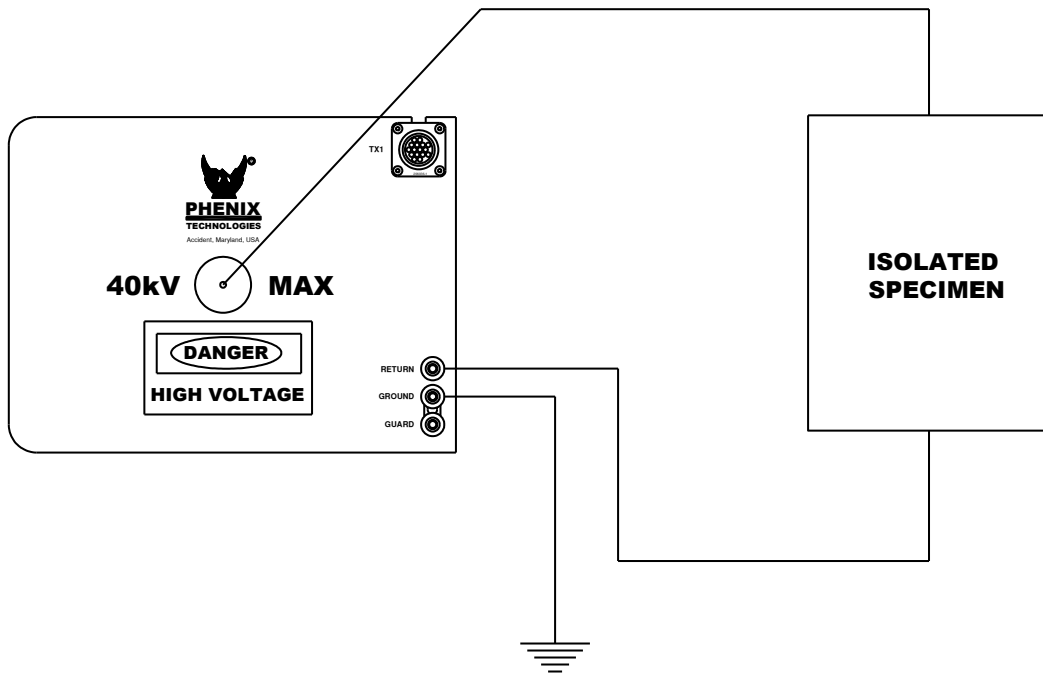
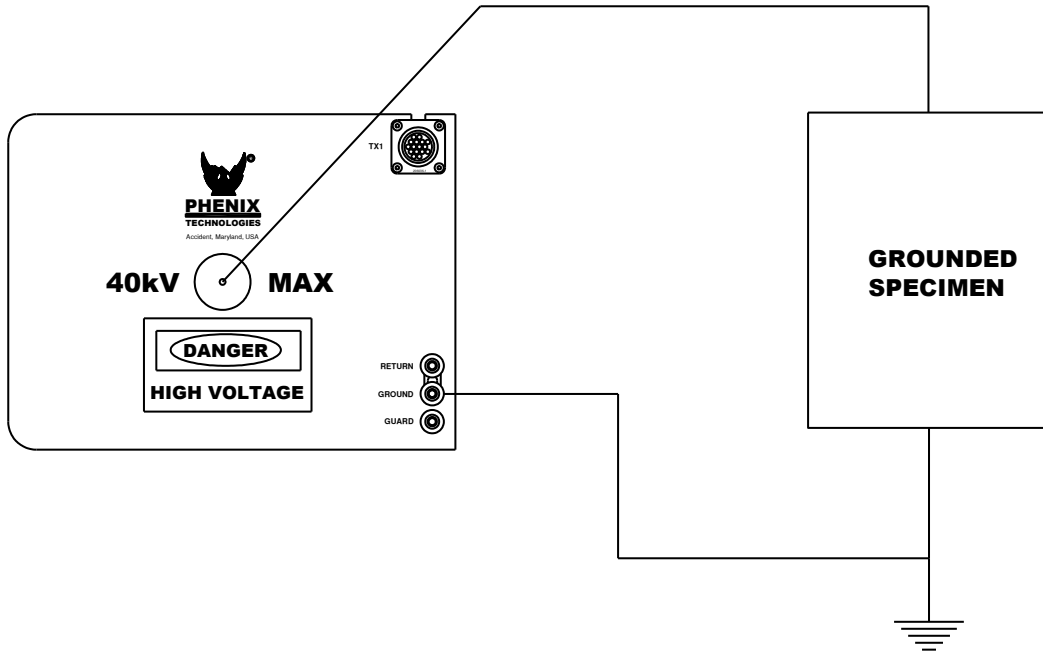

## GROUND-GUARD-RETURN CONNECTIONS

The base of the High Voltage transformer contains a currentmeter feature useful in measurement of different current sources.

### 1. **Standard Mode (RTN)**

The standard configuration is set up to measure the current from the high potential side of the unit under test to ground. This configuration **must** be used if it is not possible to isolate the low voltage side of the object under test from ground.

The low potential side of the unit under test is connected directly to ground. The binding post Jumper Clip is installed between the "Ground" and the "Return" posts on the H. V. Transformer.

This measures the output current flowing from the high voltage output through the unit under test to ground and the current meter then senses the return current from ground to the "RTN" terminal of the high voltage transformer.

### 2. **Guard Mode**

For test objects that can be fully isolated from ground it may be desirable to use the Guard Mode. In this mode only current passing through the test object will be displayed on the current meter. This will be especially important if very small currents are to be observed.

In this mode the current path does not flow directly to ground from the low potential side of the unit under test, but flows through the currentmeter first and then to ground.

The connection to be made is (1) connect the low potential side of the unit under test directly to the post marked "Return" and (2) connect the jumper clip between the "Guard" and "Ground" posts. (NOTE: Ensure the "Ground" post is grounded.)

**If the test specimen is not fully isolated from ground, the current meter will either not work, or not display accurate current readings, and this mode should not be used.**

STANDARD MODE

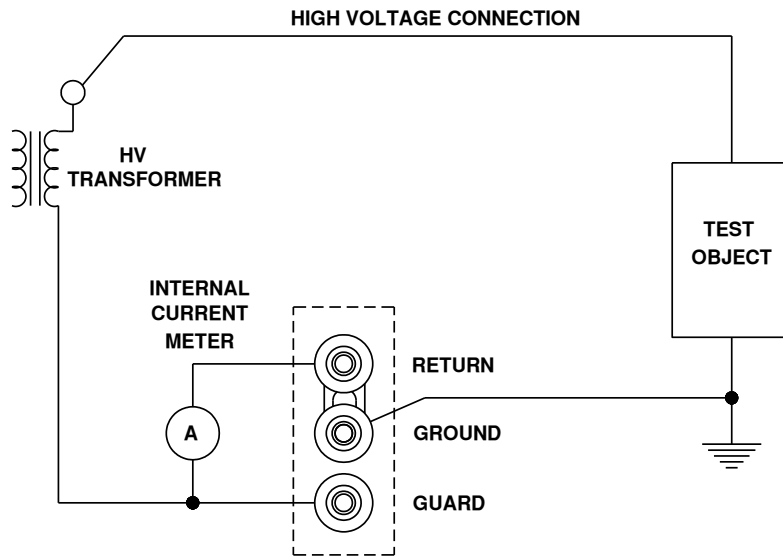

GUARD MODE

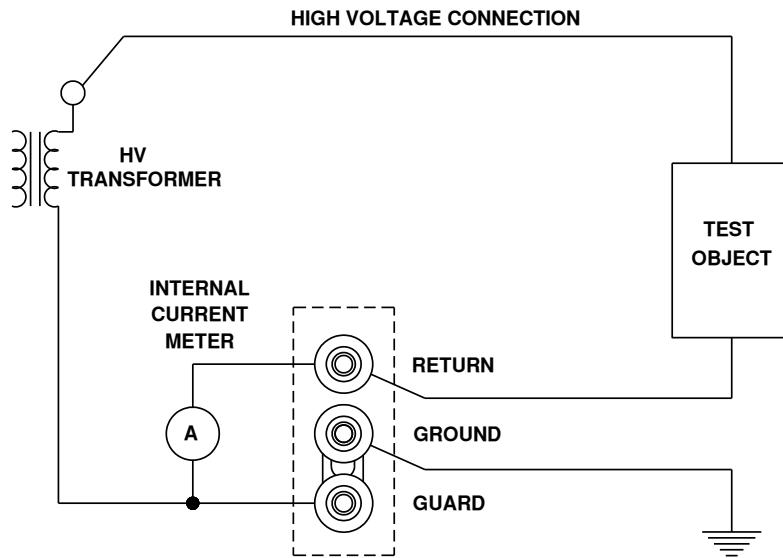

## SECTION 4: OPERATING INSTRUCTIONS

**WARNING: This unit should only be operated by personnel knowledgeable in High Voltage testing and safety procedures. Improper or careless operation of unit can result in serious injury or death.**

1. Ensure proper electrical set-up has been performed. Ensure that the testing set-up is safe for the operator and any other personnel in the area.
2. Check that the **Raise Voltage** dial is set to "0" (zero start position).
3. Set the **Current Trip** to the desired current level set point. Setting of "1" will trip off the unit when drawing approximately 10% of rated output current. Setting of "11" will trip off the unit when drawing approximately 110% of rated output current.
4. Check that the **Emergency Off** switch is in raised "ON" position.

### High Voltage Applied

5. Turn on the **power input module** switch. **HV Off** lamp should illuminate, and meters should show indication. (If not, check that Emergency Off switch is pulled up.)
6. **HV Off** lamp must be illuminated to proceed further. If not illuminated, check for open external interlock circuit (optional), and make sure **Reset** lamp is off. (Push RESET if Reset lamp is on.)
7. Press **HV On** push-button. High voltage will turn on and high voltage lamp will illuminate. (If **HV On** does not activate, recheck zero position of **Voltage Control**.)
8. Rotate the **Raise Voltage** dial and watch the Output Voltmeter and Output Currentmeter until desired levels are reached.
9. Record data, if desired, and return the **Voltage Control** to zero after testing is completed. Press **HV Off** button; high voltage will be shut off.

### Overcurrent Failure

10. If an overcurrent situation occurs, the **Reset** lamp will illuminate, and high voltage will be shut off. To regain high voltage, the **Raise Voltage** dial must be returned to zero and the **Reset** button must be depressed (lamp will extinguish).
11. After all testing is completed, turn off the **Power Input Module** switch. Remove the input power cable from the facility power.

### Emergency Off Switch

1. **Emergency Off** switch should be used in case of a necessary rapid emergency shut down. All functions are shut off.
2. **This switch must be reset after use (pulled up) to restore power to unit.**

## SECTION 5: CALIBRATION

**CAUTION:**  
 Calibration should only be done by persons familiar with High Voltage testing and safety procedures.

All calibrations have been done at the factory. Periodic calibration of the output voltmeter and output currentmeter should be done annually.

NOTE: Refer to Electrical Diagram Section for schematics pertaining to the model number of your test set.

Locating the Calibration Adjustments

The calibration points are shown in the following diagram.

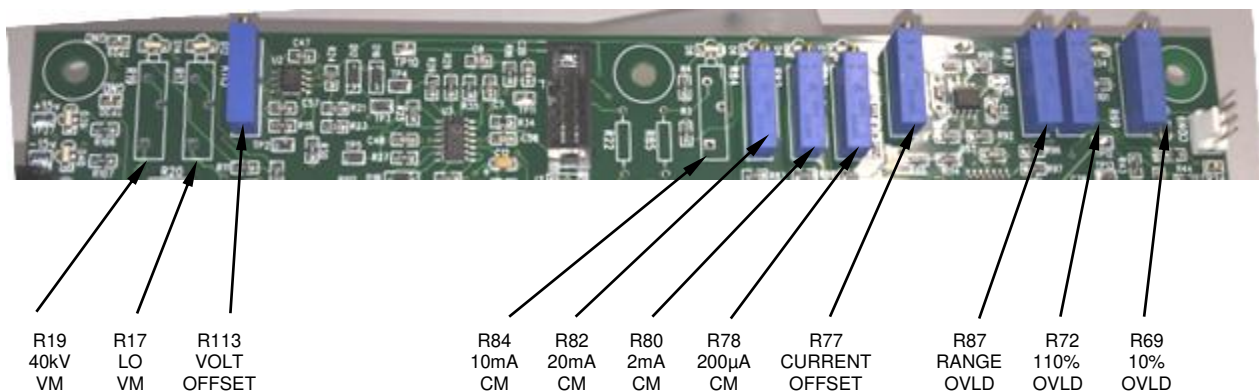

### 1. Output Voltmeter

Connect a precision high voltage voltmeter between the single range high voltage output to ground. Raise the output to approximately 80% of the rated output voltage. Adjust the reading on the panel meter (M2) by means of potentiometer R19 to a corresponding reading. Linearity may be checked at points between 10% and 100% of rated tap voltage.

### 2. Output Currentmeter

It is necessary to connect adequately rated High Voltage loads (isolated from ground) to the high voltage unit that will allow each full range current to be drawn at approximately 15% or higher output voltage. This allows sufficient resolution to adjust current levels.

Connect a precision ammeter between the low potential side of the appropriate high voltage load and the "GND" post. Raise the output to approximately 80% of the range. Adjust the reading on the panel meter (M1) by means of potentiometer R84 to a corresponding reading.

NOTE: An optional method is to use current injection between RTN and GND (Guard Mode).

**Do not turn High Voltage on for this method!**

## CALIBRATION

### 3. **Overcurrent**

This calibration should not need adjustment (factory adjusted). If the overcurrent circuit is out of calibration, perform the following steps.

- a. With unit off, short the output terminal to ground through an appropriate currentmeter. NOTE: A High Voltage Load will give better resolution and make calibration easier.
- b. Set the Current Trip potentiometer on the front panel to "1".
- c. Turn on HV On and adjust the output current slowly until 10% of rated current (check nameplate) is displayed on the currentmeter.
- d. Adjust potentiometer R15 until the Reset lamp illuminates and high voltage is shut off.
- e. Set the Current Trip potentiometer on front panel to "11".
- f. Turn on HV On and adjust the output current slowly until 110% of rated current is displayed on meter.
- g. Adjust potentiometer R103 until the Overload lamp illuminates and high voltage is shut off.
- h. Repeat step "B" through "G" as necessary until both settings are calibrated.

### 4. **Range Overcurrent:**

R87 sets an overcurrent for the ranges and should be set to trip at approximately 112% of full range current on medium range setting with current trip potentiometer set at "11."

NOTE: For Single Range models, the Range Overcurrent adjust is not used in calibration adjustments

### 5. **Voltage offset adjustment (R113):**

The voltage offset should be done with the voltage output lead connected to board ground. This typically can be done by connecting the output to the guard terminal. Once connected, the offset should be adjusted until the output meter reads nearest to zero. This offset adjustment should be done before adjustments to the voltage ranges are made. Test point T10 may also be used to make this adjustment.

### 6. **Current offset adjustment (R77):**

The current offset should be done with the current input connected to board ground. This typically can be done by placing a jumper from the guard to the return terminal. Once jumped, the offset should be adjusted until the output meter reads nearest to zero. This offset adjustment should be done before adjustments to the current ranges are made. Test point T37 may also be used to make this adjustment.

## SECTION 6: TROUBLESHOOTING

### General

If the controls do not operate properly after having been used according to the instructions, the following hints may help.

- Check main facility input power to the test set.
- Check that the Emergency Off switch is in up position.
- Check indicating lamps. (Spare lamps are available through Phenix Technologies.)
- Check operation of Power Input Module switch. HV Off lamp and meters should be on.
- Check F1 if no function at all and F2 if all control functions work but no High Voltage present.
- Check all plug connections, internal and external, on the test set.
- Check external interlock circuit if applicable.

### Specific Problems

#### 1. High voltage cannot be turned on?

- External Interlock is open. (if applicable)
- Raise Voltage dial is not in lower limit position.
- Current Trip circuit is not Reset.
- Faulty relay contacts.
- Faulty HV On switch.
- Faulty HV Off switch.

#### 2. Voltage control inoperable?

- F2 Open
- High voltage is not on (K8 not energized or see number 1 above).
- Faulty variable autotransformer "T1".
- Faulty interconnect cable or connection.
- Faulty high voltage transformer.

#### 3. Current Trip inoperable?

- Defective interconnect cable.
- Improper sensitivity (adjust Current Trip (R15) on front panel).
- Defective U13 on PCB 1387.
- Check the +15 volts DC and -15 volts DC regulator (U16, U17).
- Check signal input voltage to PCB 1387 at Con 4:6.
- Check LP4 (RESET) and relay K7 on PCB 1387.



## TROUBLESHOOTING

### 4. **Currentmeter inoperable?**

- Unit connected in "Guard" Mode with specimen grounded.
- Improper Guard/Ground/Return connections.
- Defective interconnect cable (J1) (Controls to HV unit.)
- Connection between currentmeter and high voltage test specimen open.
- Connectors on PCB1387 or meter not fully engaged, or defective meter cable.
- Meter damaged.

### 5. **Voltmeter inoperable?**

- Defective interconnect cable. (J1) (Controls to HV unit.)
- Output shorted to ground.
- Meter damaged.
- No high voltage present at output.
- Connectors on PCB1387 or meter not fully engaged, or defective meter cable.

### 6. **No output voltage from high voltage section?**

- Faulty interconnect cable.
- Defective metering circuit.
- No input to voltage regulator section, possible problems with K8/ K9 contacts, regulator (T1), or with F2.
- Internal connection broken.
- Defective high voltage output transformer.

## **SECTION 7: STORAGE OF EQUIPMENT**

If the equipment will be stored for a prolonged period, the following precautions are recommended.

1. The equipment should be covered and kept in a warm, dry environment (95% maximum humidity, 5 to 50 degrees C).
2. In no case should the test unit be stored outdoors (unless previously specified in the original purchase agreement).

## SECTION 8: CIRCUIT DIAGRAM SYMBOLS

CIRCUIT DIAGRAM SYMBOLS  
SYMBOLS POUR SCHEMA DE CIRCUIT  
SYMBOLE ZU SCHEMA

REF	SYMBOL	DESCRIPTION	DESCRIPTION	BEMENKUNG
A		Amplifier	Unite d'amplificateur	Verstärker
ARSR		Surge Arrestor	Parafoudre	Ueberspannungsableiter
C		Capacitor	Condensateur	Kondensator
BSHG		Bushing	Tranversée	Durchfuehung
C		Electrolytic Capacitor	Condensateur électrol	Eleckrolytik kondensator
F		Fuse	Fusible	Sicherung
CT		Current Transformer	Transformateur de Courant	Stromtransformer
CB		Circuit Breaker	Intérupteur	Unterbrecher
K		Relay, Contactor	Relais, Contacteur	Relais, Schütz
L		Inductor	Self	Drossel, Spule
MOT		Motor	Moteur	Motor
MOV		Movistor	Parafoudre	Movistor
NE		Neon	Parafoudre	Ueberspannungsableiter
LP		Lamp, Indicator	Lampe	Meldeleuchte
R		Resistor	Resistance	Widerstand
R		Variable Resistor	Resistance Variable	Widerstand
T		Transformer	Transformateur	Transformer
TB		Terminal Block	Borne	Lesbare Klemme
X		Connector	Prise de Courant	Steckverbindung
K		Relay Contact Normally Open	Contact Normalement Ouvert	Schlierskontakt
K		Relay Contact Normally Closed	Contact Normalement Fermé	Oeffnungskontakt
K		Changeover Contact	Contact de Changement	Umschaltkontakt
		Shielded Wire	Cable blindé	Abgeschirmetes Kabel
TR		Transistor	Transisteur	Transistor
M		Analog Meter	Instrument Analogue	Analog Meter
D		Diode	Diode	Diode
Z		Zener	Diode Zener	Zener
SCR		Thyristor	Thyristor	Thyristor
SW		Normally Open Maintained Switch	Interrupteur Normalement Maintenu Ouvert	Schrittschalter (Schliesser)
SW		Normally Closed Maintained Switch	Interrupteur Normalement Maintenu Fermé	Schrittschalter (Oeffner)
SW		Normally Closed Momentary Switch	Interrupteur Normalement Fermé Momentanement	Druckschalter (Oeffner)
SW		Normally Open Momentary Switch	Interrupteur Normalement Ouvert Momentanement	Druckschalter (Schliesser)
DP		Current Overload Device	Dispositif De Sûr Intensité	UeberstromschutzEinheit

**SECTION 9: ELECTRICAL DIAGRAMS**

<u>Drawing Number</u>	<u>Description</u>
1. 9607021 (SHEET 1/2)	640-0.4P Unit Schematic

INTENTIONALLY BLANK PAGE

## SECTION 10: PARTS LIST

ITEM	DESCRIPTION	QTY	PART NO.
	<b>CONTROLS</b>		
CORD	INPUT POWER CORD	1	1077170
D3-5	DIODES	3	1780025
F1 (120V), F2	5 AMP FUSE	2	1603605
F1 (220V)	3 AMP FUSE	1	1603603
F2	FUSE HOLDER	1	1603920
K1	KUP 3 POLE RELAY	1	1700610
LP2	LAMP 24V RED	1	1420162
LP3	LAMP 24V GREEN	1	1420161
LP4	LAMP 24V WHITE	1	1420163
M1,M2	3 ½ DIGIT LCD METER	2	1506400
M1,M2	METER PROTECTION ASSY	2	31138800
M1,M2	METER PLUG	4	1152152
M1,M2	RIBBON CABLE	2FT	1079909
C1-3	.27 $\mu$ f, 50 VDC CAPACITOR	3	1093175
D7,D12	ZENER DIODES, 5.6V	6	1780034
PCB1387 ASSY.	CONTROL / METERING BOARD	1	31138710
R7	10K, 2W LINEAR POTENTIOMETER	1	1761098
R7 DIAL	BLACK STATOR	1	1355905
R7 DIAL	0-11 NUMBERED DIAL	1	1355910
R7 KNOB	BLACK KNOB	1	1355101
R7 CAP	KNOB CAP	1	1355102
LP2 LENS	RED LENS EAO	1	1422150
LP3 LENS	GREEN LENS EAO	1	1422151
LP4 LENS	YELLOW LENS EAO	1	1422152
SW2,3,4	PUSHBUTTON SWITCH, 1 POLE, MOMENTARY	3	1860120
SW7	ROLLER CAM MICRO SWITCH, ZERO START	1	1866015
SW8	N.C. CONTACT BLOCK	1	1862905
SW8	MUSHROOM SWITCH OPERATOR	1	1862116
SX1	4 FEMALE PIN CHASSIS CONN. (Ext. Intlk)	1	1151152
SX1	FEMALE PINS	2	1151174
SX1 PLUG	4 MALE PIN CABLE CONN.	1	1151162
SX1 PLUG	CABLE CLAMP	1	1151186
SX1 PLUG	SOLDER TYPE MALE PINS	2	1151176
T1	STACO 221-B VARIABLE TRANSFORMER	1	1890105
J1 CABLE-COMplete	INTERCONNECT CABLE	1	30160003
T3 (220V)	230-115V AUTO TRANSFORMER	1	1894428
J1	J1 RECEPTACLE - 14 PIN	1	1151156
J1	FEMALE PINS - CRIMP	7	1151175
J1	FEMALE PINS - SOLDER	7	1151177
POWER MODULE / SW1	CORCOM GVM1S	1	1152591
MOV1	130V MOVISTOR	1	1606100
	<b>HV UNIT</b>		
GND CABLE	10 FT. GROUND CABLE ASSY.	1	30080023
RETURN CABLE	10 FT. RETURN CABLE ASSY.	1	30080009
HV CABLE	10 FT. HV CABLE ASSY.	1	30070006
R1 A, B	150 MEG, 6 W, 1%RESISTOR	2	1748350

## PARTS LIST

ITEM	DESCRIPTION	QTY	PART NO.
	<b>HV UNIT (continued)</b>		
R2,	.5 W, 1 K, 1%	1	1721960
R3	.5 W, 680 OHM, 1%	1	1721345
SG1-4	90 V SPARK GAP	4	1605110
T2	HIGH VOLTAGE TRANSFORMER	1	GA1-1935
D1-D4	1.5KE18A TRANSORB	4	1780065
CASE	GEMINI CASE	1	2100524
BINDING POST - GND	GREEN BINDING POST	1	1351103
BINDING POST - GND	BLACK BINDING POST	1	1351100
BINDING POST - RTN	RED BINDING POST	1	1351102
BINDING POST - GRD	WHITE BINDING POST	1	1351104
J1	CHASSIS RECEPTACLE - 16 PIN	1	1151158
J1	MALE PINS - CRIMP	8	1151172
J1	MALE PINS - SOLDER TYPE	8	1151176

## **SECTION 11: PARTS ORDERING INFORMATION**

Replacement parts are available from Phenix Technologies, Inc.

Changes to Phenix Technologies' products are sometimes made to accommodate improved components as they become available, and to give you the benefit of the latest technical improvements developed in our Engineering Department. It is, therefore, important when ordering parts to include the serial number of the unit as well as the part number of the replacement part. When your purchase order is received at our office, a representative of Phenix Technologies will contact you to confirm the current price of the part being ordered. If a part you order has been replaced with a new or improved part, an Applications Engineer will contact you concerning any change in part number.

Your order for replacement parts should be sent to:

Service Department  
Phenix Technologies, Inc.  
75 Speicher Drive  
Accident, Maryland 21520



## SECTION 12: RECOMMENDED SPARE PARTS

Phenix Technologies recommends that the customer purchase and stock the following parts for normal maintenance of the unit. The recommended quantity should be sufficient to support the unit during normal operation.

If the unit will be operated at an isolated site for an extended period or will be subjected to unusual stresses, a larger quantity of parts should be stocked as spares. In such a case, contact your Phenix Technologies' sales representative for a recommendation.

Current prices may be obtained by contacting the Parts Ordering Department at Phenix Technologies.

<u>Part Name</u>	<u>Part Number</u>	<u>Recommended Quantity</u>
Digital Panel Meter, KNS 3 ½ digit LCD	1506400	1
Zero Start Switch, V3L-121-D8	1866005	1
F1: 120V, F2 120/220V 5A	1603605	2
F1: 220V, 3 A	1603601	2
HV ON, HV OFF, RESET Switch – EAO	1860120	1
Interconnect Cable	30160003	1
High Voltage Cable	30070006	1
Ground Cable	30080023	1
Return Cable	30080009	1
Led 24V White	1420163	1
Led 24V Red	1420162	1
Led 24V Green	1420161	1

## **SECTION13: RETURNED MATERIAL**

If for any reason it should become necessary to return this equipment to the factory, the Service Department of Phenix Technologies, Inc. must be given the following information:

Name Plate Information  
Model Number  
Serial Number  
Reason for Return  
Cause of Defect

If Phenix Technologies, Inc. deems return of the part appropriate, it will then issue an "Authorization for Return". If return is not deemed advisable, other inspection arrangements will be made. NOTE: Material received at this plant without the proper authorization shall be held as "Customer's Property" with no service until such time as the proper steps have been taken.

Your cooperation is requested in order to ensure prompt service.