



AC DIELECTRIC TEST SET MANUAL
600P SERIES

Model Number 6CP30/15-3

Version 4.3

PHENIX TECHNOLOGIES, INC
A Division of Doble Engineering
75 Speicher Drive
Accident, MD 21520

Copyright © Phenix Technologies, Inc.

TABLE OF CONTENTS

<u>DESCRIPTION</u>	<u>SECTION NUMBER</u>
DANGER / GENERAL SAFETY PRECAUTIONS	
TECHNICAL SPECIFICATIONS	1
CONTROLS AND INDICATORS	2
ELECTRICAL SET-UP	3
OPERATING INSTRUCTIONS	4
CALIBRATION	5
TROUBLESHOOTING	6
TRANSPORTING / STORAGE OF EQUIPMENT	7
CIRCUIT DIAGRAM SYMBOLS	8
ELECTRICAL DIAGRAMS	9
PARTS LIST	10
PARTS ORDERING INFORMATION	11
RECOMMENDED SPARE PARTS	12
RETURNED MATERIAL	13
CUSTOMER COMMENTS/ SUGGGESTIONS	14
ATTACHMENTS	
TAD1U TIMER MANUAL	

DANGER / WARNINGS
WARNING !!

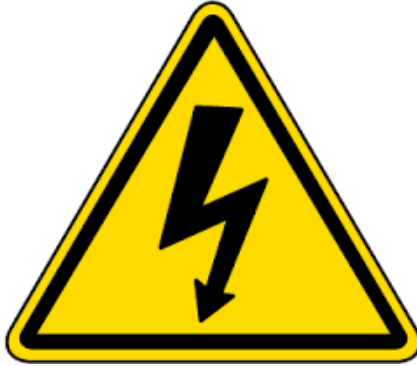

DANGER

Grounding of this unit is necessary for the safe operation of this equipment. Disconnect inputs before ungrounding this equipment.

DANGER / WARNINGS

GENERAL SAFETY PRECAUTIONS



This equipment can produce POTENTIALLY LETHAL VOLTAGES!
Improper operation or test practices may result in injury or death to the operator or surrounding personnel.

The operation of High Voltage test equipment should only be performed by personnel familiar with HIGH VOLTAGE testing and safety procedures. The operator of this equipment must be aware of all hazards associated with High Voltage testing. The operator is responsible for himself and others in close proximity of the testing area.

Some General Safety Practices for working with High Voltage Test Equipment have been listed below for your reference.

- **Become familiar with your instrument before performing an actual test**
- **Know your work area, check that all circuits are de-energized and locked out.**
- **Never work alone; always work with another qualified worker.**
- **Mark off entire work area with barriers and warning tape.**
- **Make all personnel aware of your testing activities.**
- **Be aware of dangerous conditions that may arise from energizing a test specimen.**
- **Never modify test equipment, modifications to equipment could introduce an unknown hazard or hinder a designed-in safety feature.**
- **DO NOT operate damaged equipment. Remove power, and do not use the equipment until safe operation can be verified by service-trained personnel.**

Phenix Technologies, Inc. assumes no liability for unsafe or improper use of test equipment.

SECTION 1: TECHNICAL SPECIFICATIONS



Input

110-120 volts, 50/60 Hz, single phase, 1.9kVA, 16 amperes
OR
220-240 volts, 50/60 Hz, single phase, 1.9 kVA, 8 amperes

Output Rating

15 kilovolts, 200 mA
30 kilovolts, 100 mA

Duty Cycle

5 MINUTES ON / 15 MINUTES OFF at 3 kVA
15 MINUTES ON / 1 HOUR OFF AT 2 kVA
1 HOUR ON / 1 HOUR OFF at 1.5 kVA

Type of Cooling

ONAN (Oil-Natural / Air-Natural Convection)

Distortion

Less than 5 percent at full load

Impedance

Less than 10 percent at rated current

Operating Ambient Temperature

0-40 degrees Celsius

Output Termination

Toroid

Metering

Output Voltmeter: Display: 3 ½ digit LCD
Accuracy: \pm (0.8% of Reading + 0.2% of Range) + LSD (10-100% of Range)
Ranges: 0 to 15kV / 30 kV
Type: Peak/(Square root of 2)

Output Currentmeter: Display: 3 ½ digit LCD
Accuracy: \pm (0.8% of Reading + 0.2% of Range) + LSD (10-100% of Range)
Ranges: 0 to 200 μ A / 2mA / 20mA / 200mA
Type: True RMS

Sizes and Weights

Control Section: 16.5" (419 mm) W x 15.25" (388 mm) D x 11.25" (286 mm) H
Weight: 30 pounds (14 kg)

HV Transformer: 14" (356 mm) W x 14" (356 mm) D x 17" (429 mm) H
Weight: 76 pounds (34 kg)

SECTION 2: CONTROLS AND INDICATORS

Figure 2-1

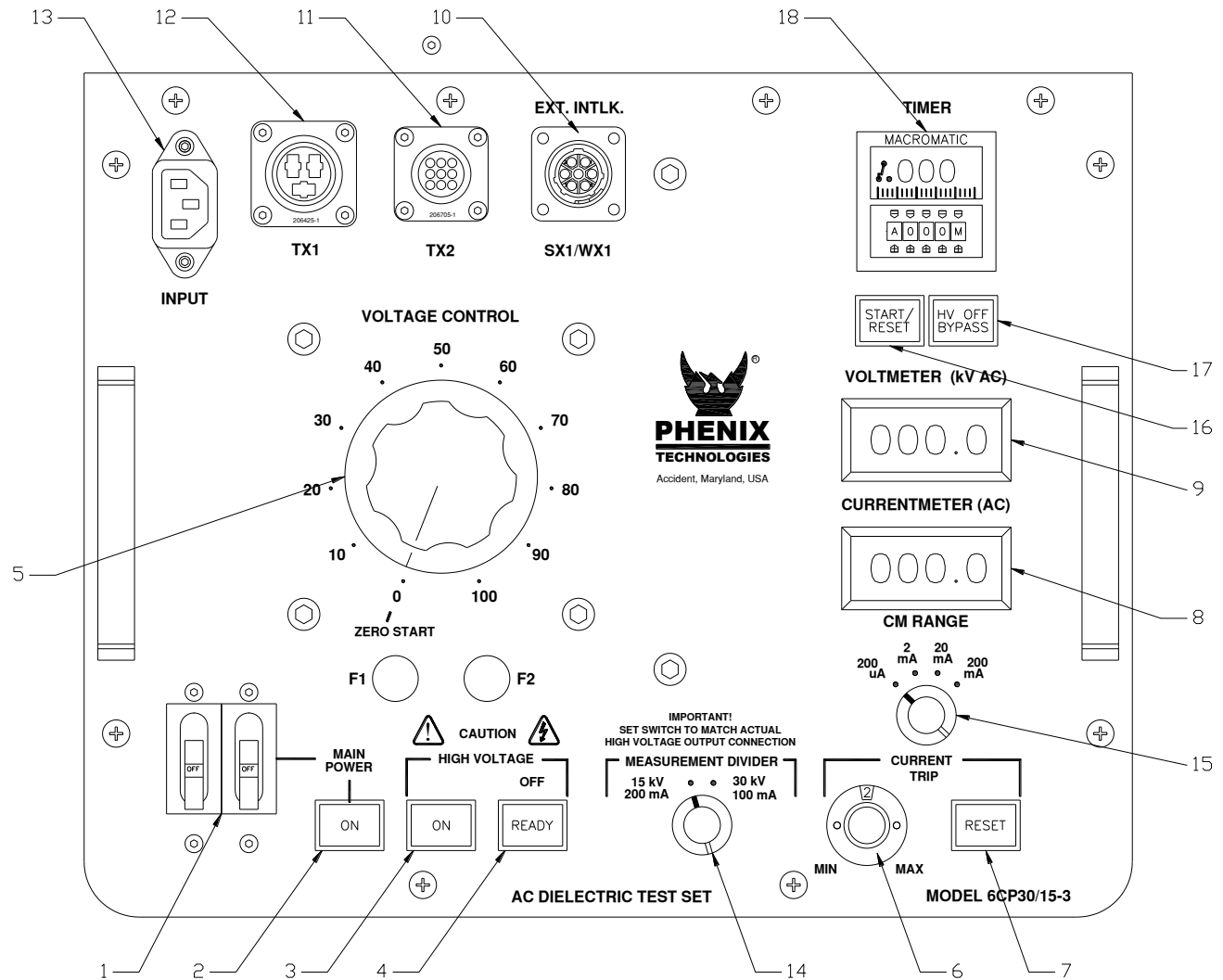

Control Panel: The following descriptions are keyed to Figure 2-1

- 1. Main Power Circuit Breaker.** Turns main power of unit on and off and provides input overload protection.
- 2. Main Power Lamp.** Illuminates to indicate input power is supplied to unit.
- 3. High Voltage On.** Momentary switch activates power to high voltage circuits when prerequisite conditions are met. **Ready** lamp (4) must be illuminated before **High Voltage On** switch will operate. See requirements for **Ready** lamp under step 4. **High Voltage On** lamp illuminates to indicate high voltage circuits are energized.

CONTROLS AND INDICATORS

Control Panel (Cont'd)

4. **High Voltage Off/Ready.** Momentary switch turns high voltage off when activated. **Ready** lamp illuminates when all pre-conditions required for high voltage activation are met.

Conditions required for **Ready** lamp illumination are:

- Power applied to unit and **Main Power Breaker** (1) on, **Main Power** lamp illuminated (2).
 - **External Interlock** circuit series loop must not be open (10).
 - **Voltage Control** (5) must be at zero. (Zero Start.)
 - Overcurrent circuit must be reset if **Reset** lamp is illuminated (7).
5. **Voltage Control.** Turn clockwise to raise output voltage. High voltage cannot be activated if **Voltage Control** is not started at zero.
6. **Overcurrent Trip Adjust.** Dial adjusts from 1 to 11 corresponding to 10% to 110% of rated output current. **Overcurrent Trip/Reset** lamp illuminates and high voltage turns off when output current exceeds setting, causing circuit to trip. Circuit also acts as short circuit and overload protection on high voltage output. To reactivate high voltage, **Voltage Control** (5) must be returned to zero, and **Overcurrent Reset** switch (7) must be pressed to clear overcurrent circuit.
7. **Overcurrent Reset.** **Reset** lamp illuminates to show that overcurrent circuit has tripped. High voltage circuits are deactivated. Momentary **Reset** switch must be pressed to extinguish **Reset** lamp to allow high voltage to be reapplied after returning **Voltage Control** (5) to zero.
8. **Currentmeter.** Displays output current of test set, units based on current meter range setting.
9. **Voltmeter.** Displays output voltage of test set, units in kilovolts.
10. **Ext. Intlk. – SX1/WX1.** Provides for user connection of external interlock or auxiliary safety control device such as emergency off switch, gate switch, foot switch, dead man switch, etc. Included plug has shorting jumper installed to complete circuit. Jumper must be removed, and cable connected to user supplied device by user if desired to use this provision. Only non-energized switch or dry relay contact devices may be used. This is a series 120VAC circuit that must remain closed for high voltage to be activated. An optional warning light accessory is available to plug into this connector while also making use of the security circuit via a passthrough connector
11. **TX2.** Provided interconnect cable is connected here and to the same designation connector on the high voltage unit. This is the metering and return connection. **Do not attempt to operate high voltage unit without this cable connected at both ends.**
12. **TX1.** Provided power interconnect cable connects here and to the same designation connector on high voltage unit.
13. **Line Cord.** Supplies input power to unit.

CONTROLS AND INDICATORS

Control Panel (Cont'd)

14. **Measurement Divider.** Setting of this switch determines the voltage measurement divider ratio. This switch *must* be set to match the actual high voltage output connection.

WARNING! If a test specimen intended to be tested at 10kV is connected to the 30kV output and the **Measurement Divider** switch is set to 15kV, the actual voltage applied to the specimen will be approximately 2 times the indicated voltage on the panel meter and an over-voltage may be applied to the test specimen.

15. **CM Range.** Turn to select the desired current measurement range.
16. **Start/Reset.** Press to start the timer after test voltage has been reached. Press again to reset the timer to the original setting.
17. **HV Off Bypass.** Press to allow high voltage to remain on after timer has expired. Indicator lights when depressed.
18. **Timer.** Select desired test time using buttons on face of timer. See manual attachment.

SECTION 3: ELECTRICAL SET-UP

WARNING !

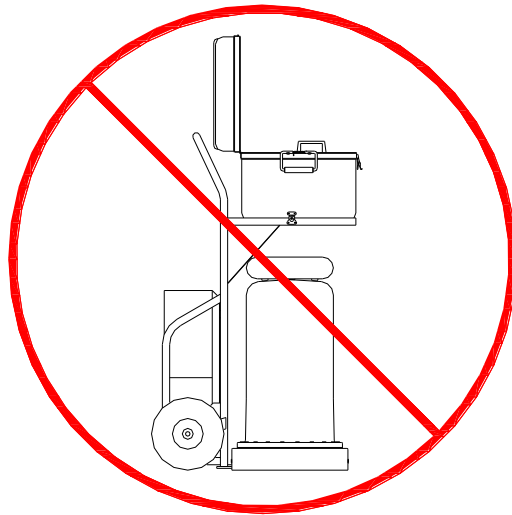

DO NOT OPERATE THE TEST SET
WITHOUT REMOVING HIGH-VOLTAGE
TRANSFORMER FROM THE CART.

THE HIGH-VOLTAGE TRANSFORMER
MUST BE POSITIONED A SAFE DISTANCE
FROM PERSONNEL AND OTHER OBJECTS.

WARNING:
Be sure the Main Power plug of the control unit is unplugged before proceeding

1. Locate the desired location for the test set. Prepare the main power input cable for plugging in to the proper facility power (i.e., 120 volts AC or 220 volts AC). Leave plug unconnected at this time.
2. Connect a sufficient ground from the ground stud on the base of the high voltage transformer to a proper facility ground using a low inductance cable rated for 20 amperes or greater, or the supplied 10 AWG GND cable.
3. Connect **TX1** and **TX2** interconnect cables between controls and high voltage transformer.
4. External Interlock

If an external interlock is not to be used, plug the connector as supplied into the socket on the control panel marked **EXT INTLK, SX1**, if not already in place.

If an external interlock is to be used, remove the jumper on the plug of the "**EXT INTLK**" circuit and connect the external security circuit at these points. (NOTE: The external interlock circuit must consist of a closed loop of dead contacts. When the control power is on, the external circuit will be energized with 120 volts AC.)

High Voltage Connection

WARNING:
Main power circuit breaker on the front panel must be in the OFF position before proceeding. Test specimen must be de-energized and discharged.

1. Connect the low side (return) of test specimen to the return post with the provided red test lead. See Ground-Guard-Return connection instructions on following pages.
2. Connect the high side of test specimen to either the toroid on top of HV tank (for 30kV output) or the 15kV connection on the side of the tank. Be sure that the **Measurement Divider** switch on the control panel is set to match the high voltage connection being made.
3. Check that control circuit breaker is turned off and connect input main power cable to a suitable grounded receptacle

Brief connection instructions and diagram are on following pages.

ELECTRICAL SET-UP

CONNECTIONS AND GROUNDING (QUICK REFERENCE)

- Position set in the desired location.
- Ground set by use of ground terminal on base of high voltage transformer.
- Connect **TX1** and **TX2** cables between controls and high voltage transformer.
- Connect **SX1** - external interlock circuit as appropriate.
- Connect return lead, provided, to low potential side of test specimen. See Ground-Guard-Return connection instructions on following pages.
- Connect high potential side of test specimen to either the 15kV (side) or 30kV (top) high voltage output.
- Connect main power cord to appropriate receptacle.

(Further instructions on test connections may be found in ANSI C37.60)

ELECTRICAL SETUP

GROUND-GUARD-RETURN CONNECTIONS

The base of the High Voltage transformer contains a currentmeter feature useful in measurement of different current sources. (Refer to Figure (3-1.)

1. Return Mode (Standard Mode)

The standard configuration is set up to measure the current from the high potential side of the unit under test to ground. This configuration **must** be used if it is not possible to isolate the low voltage side of the object under test from ground.

This measures the output current flowing from the high voltage output through the unit under test to ground **and** the current meter then senses the return current from ground to the "RTN" terminal of the high voltage transformer.

The low potential side of the unit under test is connected directly to ground. **The binding post Jumper Clip is installed between the Ground ("GND") and the Return ("RTN") posts on the base of the H. V. Transformer.**

2. Guard Mode

For test objects that can be fully isolated from ground it may be desirable to use the Guard Mode. In this mode **only current passing through the test object will be displayed on the current meter.** This will be especially important if very small currents are to be observed.

In this mode the current path does not flow directly to ground from the low potential side of the unit under test but flows through the currentmeter first and then to ground.

For Guard Mode operation, connect the low potential side of the unit under test directly to the Return post ("RTN") and **connect the jumper clip between the Guard ("GRD") and Ground ("GND") posts** that are located on the base of the HV Transformer.

(NOTE: Ensure the Ground ("GND") post is grounded.)

CAUTION

If the test specimen is not fully isolated from ground, the current meter will either not work, or will not display accurate current readings, and this mode should not be used.

ELECTRICAL SETUP

Figure 3-1

RETURN / STANDARD MODE

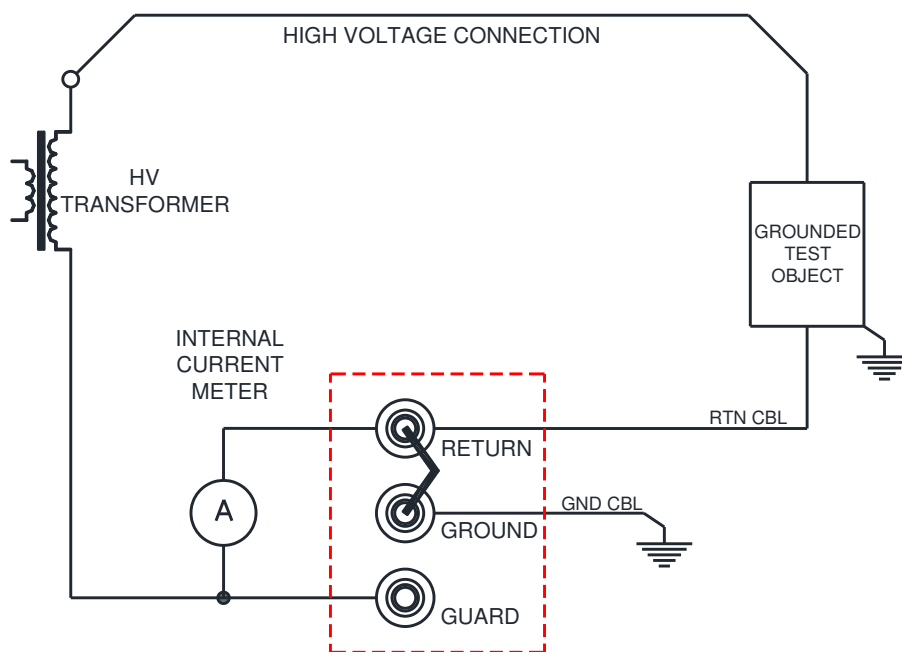

GUARD MODE

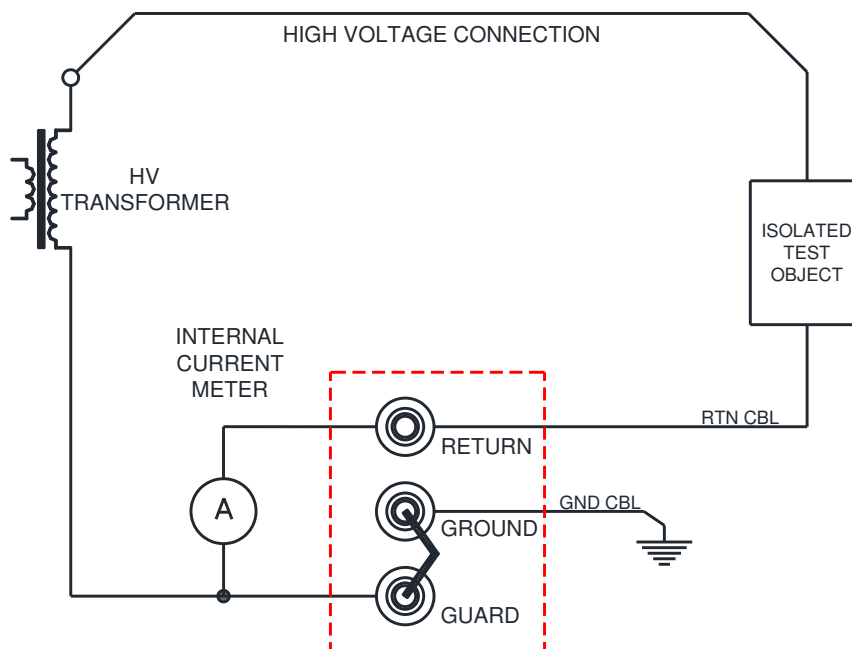

SECTION 4: OPERATING INSTRUCTIONS

WARNING:

This unit should only be operated by personnel knowledgeable in High Voltage testing and safety procedures. Improper or careless operation of unit can result in serious injury or death.

1. Ensure proper electrical set-up has been performed. Ensure that the testing set-up is safe for the operator and any other personnel in the area.
2. Check that the **Raise Voltage** dial is set to "0" (zero start position).
3. Set the **Overcurrent Trip** to the desired current level setpoint. Setting of "1" will trip off the unit when drawing 10% of rated output current. Setting of "11" will trip off the unit when drawing 110% of rated output current.

High Voltage Applied

4. Turn on the front panel circuit breaker. Control Power lamp will illuminate.
5. Ready lamp must be illuminated to proceed further. If not illuminated, check zero start (Step 2 above), check for open external interlock circuit, and make sure overcurrent lamp is off. (Push RESET if overcurrent lamp is on.)
6. Press HV On push-button. High voltage will turn on and high voltage lamp will illuminate.
7. Rotate the Raise Voltage dial and watch the Output Voltage and Output Currentmeter until desired levels are reached.
8. Record data, if desired, and lower the output after testing is completed. Press HV Off button; high voltage will be shut off.

Overcurrent Failure

9. If an overcurrent situation occurs, the overcurrent lamp will illuminate, and high voltage will be shut off. To regain high voltage, the Raise Voltage dial must be returned to zero and the Overcurrent Reset button must be pressed (lamp will extinguish).
10. After all testing is complete, turn off the front panel circuit breaker. Remove the input power cable from the facility power input.

SECTION 5: CALIBRATION

CAUTION: Calibration should only be done by persons familiar with High Voltage testing and safety procedures.

All calibrations have been done at the factory. Periodic calibration of the output voltmeter and output currentmeter should be done annually.

NOTE: Refer to Electrical Diagram Section for schematic pertaining to the model number of your test set.

Locating the Calibration Adjustments

The calibration points are shown in the following diagram.

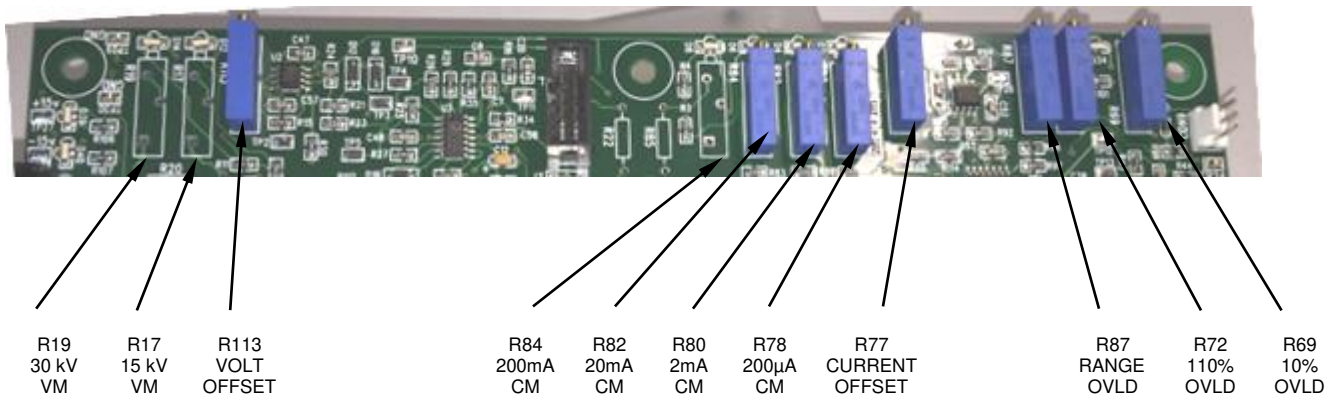

NOTE:

Calibration potentiometers are set at the factory and should not be adjusted.

1. Output Voltmeter

Voltmeter is peak responding calibrated to $\text{Peak}/\sqrt{2}$ (RMS value of sine wave).

15kV Range: Connect a precision high voltage voltmeter between the 15kV output (side of tank) to ground. Be sure the **Measurement Divider** switch on the control panel is in the 15kV position. Raise the output to approximately 80% of the rated output voltage. Adjust the reading on the panel meter (M2) by means of potentiometer R17 to a corresponding reading. Check linearity at several points from 20% to 100% of rated tap voltage.

30kV Range: Connect a precision high voltage voltmeter between the 30kV output (top of tank) to ground. Be sure the **Measurement Divider** switch on the control panel is in the 30kV position. Raise the output to approximately 80% of the rated output voltage. Adjust the reading on the panel meter (M2) by means of potentiometer R19 to a corresponding reading. Check linearity at several points from 20% to 100% of rated tap voltage.

CALIBRATION

2. Output Currentmeter

It is necessary to connect adequately rated High Voltage loads (isolated from ground) to the high voltage unit that will allow each full range current to be drawn at approximately 15% or higher output voltage. This allows sufficient resolution to adjust current levels.

Place Binding Post Configuration in GUARD MODE. (Jumper clip is installed between GRD and GND posts.)

Connect a precision ammeter between the low potential side of the appropriate high voltage load and the RTN post. Select the 200 μ A currentmeter range. Raise the output to approximately 80% of the range. Adjust the reading on the panel meter (M1) by means of potentiometer R78 to a corresponding reading. Repeat for 2mA, 20mA and 300mA ranges adjusting R80, R82 and R84, respectively. (High Voltage load will need to change when changing range).

An optional method is to use current injection between RTN and GND (Guard Mode). ***Do not turn High Voltage On for this method!***

3. Overcurrent

This calibration should not need adjustment (factory adjusted). If the overcurrent circuit is out of calibration, perform the following steps.

- a. With unit off, short the output terminal to ground through an appropriate currentmeter. NOTE: A High Voltage Load will give better resolution and make calibration easier.
 - b. Set the Current Trip potentiometer on the front panel to "1" and current range switch to High.
 - c. Turn on HV On and adjust the output current slowly until 10% of rated current (check nameplate) is displayed on the currentmeter.
 - d. Adjust potentiometer R69 until the Reset lamp illuminates and high voltage is shut off.
 - e. Set the Current Trip potentiometer on front panel to "11."
 - f. Turn on HV On and adjust the output current slowly until 110% of rated current is displayed on meter.
 - g. Adjust potentiometer R72 until the Overload lamp illuminates and high voltage is shut off.
 - h. Repeat steps a through g as necessary until both settings are calibrated.
4. Range Overcurrent. R87 sets an overcurrent for the ranges and should be set to trip at approximately 110% of full range current on medium range setting with current trip potentiometer set at "11."

SECTION 6: TROUBLESHOOTING

General

If the controls do not operate properly after having been used according to the instructions, the following should be checked.

- Check main facility input power to the test set.
- Check indicating lamps. (Spare lamps are available through Phenix Technologies.)
- Check operation of the circuit breaker (CB1). Control Power lamp should be on when the circuit breaker is on.
- Check fuses.
- Check all plug connections on the test set, internal and external.

Specific Problems

1. High voltage cannot be turned on?

- External interlock is open.
- Raise Voltage dial is not in lower limit position.
- Protection circuit (Overcurrent) is not reset.
- Faulty relay contacts.
- Faulty HV On switch.
- Faulty Reset Switch.

2. Voltage control inoperable?

- High voltage is not on (K3 not energized or see number 1 above).
- Faulty variable autotransformer, T1.
- Faulty high voltage transformer.

3. Overcurrent inoperable?

- Improper sensitivity (adjust Overcurrent Trip, R1, on front panel).
- Defective U13 on PCB 1387.
- Check the +15 volts DC and -15 volts DC regulator (U16, U17).
- Check Overcurrent lamp and relay K7 on PCB 1387.

4. Currentmeter inoperable?

- Connections between the test set and the test specimen are open.
- Binding post jumper clip installed between ground and guard with a grounded test object.
- Current meter range switch (SW5) between detents.
- Faulty, TX1 interconnect cable.
- Meter defective.
- Faulty Circuit on PCB1387.

TROUBLESHOOTING

Specific Problems (cont'd)

5. Voltmeter inoperable?

- High voltage output shorted to ground.
- Damaged or inoperative Measurement Divider Switch.
- Meter defective.
- Faulty TX1 interconnect cable
- No high voltage present at the test set output.
- Faulty circuit on PCB1387.

6. No output voltage from high voltage section?

- Defective metering circuit.
- No input to voltage regulator section, possible problems with K3 contacts, variable transformer, or with CB1.
- Shorted high voltage output.
- Defective high voltage output transformer.
- Defective TX1 cable or connector.

SECTION 7: STORAGE OF EQUIPMENT

If the equipment will be stored for a prolonged period, the following precautions are recommended.

1. The equipment should be covered and kept in a warm, dry environment (95% maximum humidity, 5 to 50 degrees C).
2. In no case should the test unit be stored outdoors, unless previously specified in the original purchase agreement.

SECTION 8: CIRCUIT DIAGRAM SYMBOLS

CIRCUIT DIAGRAM SYMBOLS
SYMBOLS POUR SCHEMA DE CIRCUIT
SYMBOLE ZU SCHEMA

REF	SYMBOL	DESCRIPTION	DESCRIPTION	BEMENKUNG
A		Amplifier	Unite d'amplificateur	Verstärker
ARSP		Surge Arrestor	Parafoudre	Ueberspannungsableiter
C		Capacitor	Condensateur	Kondensator
BSHG		Bushing	Tranversée	Durchfuehung
C		Electrolytic Capacitor	Condensateur électrol	Eleckrolytik kondensator
F		Fuse	Fusible	Sicherung
CT		Current Transformer	Transformateur de Courant	Stromtransformer
CB		Circuit Breaker	Intérupteur	Unterbrecher
K		Relay, Contactor	Relais, Contacteur	Relais, Schütz
L		Inductor	Self	Drossel, Spule
MOT		Motor	Moteur	Motor
MOV		Movistor	Parafoudre	Movistor
NE		Neon	Parafoudre	Ueberspannungsableiter
LP		Lamp, Indicator	Lampe	Meldeleuchte
R		Resistor	Resistance	Widerstand
R		Variable Resistor	Resistance Variable	Widerstand
T		Transformer	Transformateur	Transformer
TB		Terminal Block	Borne	Lösbare Klemme
X		Connector	Prise de Courant	Steckverbindung
K		Relay Contact Normally Open	Contact Normalement Ouvert	Schlierskontakt
K		Relay Contact Normally Closed	Contact Normalement Fermé	Oeffnungskontakt
K		Changeover Contact	Contact de Changement	Umschaltkontakt
		Shielded Wire	Cable blindé	Abgeschirmetes Kabel
TR		Transistor	Transisteur	Transistor
M		Analog Meter	Instrument Analogue	Analog Meter
D		Diode	Diode	Diode
Z		Zener	Diode Zener	Zener
SCR		Thyristor	Thyristor	Thyristor
SW		Normally Open Maintained Switch	Interrupteur Normalement Maintenu Ouvert	Schrittschalter (Schliesser)
SW		Normally Closed Maintained Switch	Interrupteur Normalement Maintenu Fermé	Schrittschalter (Oeffner)
SW		Normally Closed Momentary Switch	Interrupteur Normalement Fermé Momentanement	Druckschalter (Oeffner)
SW		Normally Open Momentary Switch	Interrupteur Normalement Ouvert Momentanement	Druckschalter (Schliesser)
DP		Current Overload Device	Dispositif De Sûr Intensité	UeberstromschutzEinheit

ELECTRICAL DIAGRAMS

<u>Drawing Number</u>	<u>Description</u>
1. 9602030	6CP30/15-3 ELECTRICAL SCHEMATIC (120V)
2. 9602031	6CP30/15-3 ELECTRICAL SCHEMATIC (220V)

SECTION 10: 6CP30/15-3 PARTS LIST

ITEM	DESCRIPTION	QTY	PART NO.
CONTROLS			
PCB1387	PCB1387 METER/OVERLOAD BD (6CP30/15-3)	1	31138711
CB1 (220V)	CIRCUIT BREAKER, 10 AMP, 2-POLE	1	1601312
CB1 (120V)	CIRCUIT BREAKER, 20 AMP, 1-POLE	1	1601320
CORD	INPUT POWER CORD	1	1077140
D1-D5	1N4007 (1000VR, 1.0A)	5	1780025
F1	FUSE, 1 AMP	1	1603601
F1, F2	FUSE HOLDER	1	1603920
F2 (220V)	FUSE, 10 AMP	1	1603625
F2 (120V)	FUSE, 20 AMP	1	1603629
K3	CONTACTOR 30A, 3 POLE	1	1705465
K3AUX	AUXILIARY CONTRACT	1	1701500
LP1, SW7, 8 LENS	CLEAR LENS EAO	3	1422153
LP1 SOCKET	LAMP SOCKET EAO	1	1423300
M1, M2	METER, DIGITAL, 3 ½ DIGIT	2	1506400
M1, M2	METER PROTECTION BOARD PCB1388	2	31138800
M1, M2	10 PIN SOCKET CONN	2	1152152
M1, M2	RIBBON CABLE	6FT	1079909
MOV1 (220V)	MOVISTOR, V275LA40A	1	1606110
MOV1 (120V)	MOVISTOR, V130LA10A	1	1606100
P1	POWER INPUT RECEPTACLE	1	1153328
R1	POTENTIOMETER, LINEAR, 10K, 2W	1	1761098
R1 DIAL	BLACK STATOR	1	1355905
R1 DIAL	0-11 NUMBERED DIAL	1	1355910
R1 KNOB	BLACK KNOB	1	1355101
R1 KNOB	KNOB CAP	1	1355102
R2	RESISTOR, 30k, .25W	1	1722570
R3	RESISTOR, 3.0k, .25W	1	1722087
R4	RESISTOR, 300 OHMS, .5W	1	1720600
R5	RESISTOR, 30 OHMS, 3W	1	1740184
R6	RESISTOR, 30 OHMS, 3W	2	1740184
SW2 LENS	LENS, RED EAO	1	1422150
SW1 LENS	LENS, GREEN EAO	1	1422151
SW1,2,4	SWITCH, PUSHBUTTON, MOMENTARY, 1-POLE	3	1860120
SW3	SWITCH, ROLLER, CAM, ZERO START	1	1866005
SW4 LENS	LENS, BLUE EAO	1	1422148
SW5	SWITCH, ROTARY, 4-POSITION	1	1863042
SW5,6 KNOB	KNOB, ¼"	2	1355310
SW6	SWITCH, ROTARY, 2-POSITION	1	1863048
SW7	SWITCH, PUSHBUTTON, MAINTAINED, 2-POLE	1	1860265
SW8	SWITCH, PUSHBUTTON, MAINTAINED, 1-POLE	1	1860260
SX1/WX1	RECEPTACLE, 7F PINS, SIZE 13	1	1151147
SX1/WX1	CONTACT PINS, 24-20AWG, FEMALE	6	1151174
SX1/WX1 PLUG	SX1/WX1 7 PIN PLUG	1	50100018
SW1	EAO LAMP, LED, 24V, GREEN	1	1420161
SW2	EAO LAMP, LED, 24V, RED	1	1420162
LP1, SW4, SW7	EAO LAMP, LED, 24V, WHITE	3	1420163

6CP30/15-3 PARTS LIST

ITEM	DESCRIPTION	QTY	PART NO.
CONTROLS (continued)			
T1 (220V)	STACO 1220 VARIABLE TRANSFORMER	1	1890215
T1 (120V)	STACO 1210 VARIABLE TRANSFORMER	1	1890209
T2 (220V)	50 VA CONTROL TRANSFORMER	1	1896016
TMR1	TIMER	1	1480120
TX1	RECEPTACLE, HIGH CURRENT, 3F PINS, SIZE 17	1	1151179
TX1	FEMALE CONTACT PINS, 16-12AWG	2	1151184
TX2	RECEPTACLE, 9M PINS, SIZE 13	1	1151154
TX2	MALE CONTACT PINS, 24-20AWG	7	1151170
HV TRANSFORMER			
BP-GROUND	BINDING POST, GREEN	1	1351103
BP-GUARD	BINDING POST, WHITE	1	1351104
BP-RETURN	BINDING POST, RED	1	1351102
SHORTING BAR	BINDING POST SHORTING BAR	1	1351110
D3001-3004	TRANSORB, 5KP13A	4	1780066
D3005-3006	TRANSORB, 1.5KE18C	2	1780069
MOV3001 (220V)	MOVISTOR, V275LA40A	1	1606110
MOV3001 (120V)	MOVISTOR, V130LA10A	1	1606100
R3001	6W,75MEG,1% #SSX103 75MF R	1	1748200
R3002	12W, 150 MEG,1%, LEADED, (SSX103)	1	1748350
R3003, R3004	RESISTOR, 200K, 1/4W, 1%	2	1722640
R3005	RESISTOR, 30 OHM, 3W	2	1740184
SPG3001-3002	SPARK GAP, CG90L, 90V	2	1605110
T3001	HIGH VOLTAGE TRANSFORMER, GO1-3068	1	38343068
TX1	RECEPTACLE, HIGH CURRENT, 3M PINS, SIZE 17	1	1151178
TX1	MALE CONTACT PINS, 16-12AWG	2	1151182
TX1	SIZE 17 CAP	1	1151196
TX2	RECEPTACLE, 9M PINS, SIZE 13	1	1151154
TX2	MALE CONTACT PINS, 24-20AWG	7	1151170
TX2	SIZE 13 CAP	1	1151195
INTERCONNECT CABLES			
TX1 CABLE	POWER INTERCONNECT CABLE – 6 FT 7 IN.	1	30110013
TX2 CABLE	SIGNAL INTERCONNECT CABLE- 10 FT	1	30060008
GND CABLE	10 FT. GROUND CABLE ASSY.	1	30080008
RTN CABLE	10 FT. SPECIMEN RETURN CABLE ASSY.	1	30080009

SECTION 11: PARTS ORDERING INFORMATION

Replacement parts are available from Phenix Technologies, Inc.

Changes to Phenix Technologies' products are sometimes made to accommodate improved components as they become available, and to give you the benefit of the latest technical improvements developed in our Engineering Department. It is, therefore, important when ordering parts to include the serial number of the unit as well as the part number of the replacement part. When your purchase order is received at our office, a representative of Phenix Technologies will contact you to confirm the current price of the part being ordered. If a part you order has been replaced with a new or improved part, an applications engineer will contact you concerning any change in part number.

Send orders for replacement parts to:

**Service Department
Phenix Technologies, Inc.
75 Speicher Drive
Accident, Maryland 21520**

**Ph: 1 (301) 746-8118
Fax: 1 (301) 895-5570
E-mail: info@phenixtech.com**

SECTION 12: RECOMMENDED SPARE PARTS

Phenix Technologies recommends that the customer purchase and stock the following parts for normal maintenance of the unit. The recommended quantity should be sufficient to support the unit during normal operation.

If the unit will be operated at an isolated site for an extended period or will be subjected to unusual stresses, a larger quantity of parts should be stocked as spares. In such a case, contact your Phenix Technologies' sales representative for a recommendation.

Current prices may be obtained by contacting the Service Department at Phenix Technologies.

<u>Part Name</u>	<u>Computer Number</u>	<u>Recommended Quantity</u>
Digital Panel Meter, 3 ½ DIGIT LCD	1606400	1
Limit Switch, 2HBA190-1	1866005	1
Contactora, 30 A (220V)	1705462	1
Contactora, 30 A (120V)	1705463	1
Control Power Fuse, 1A	1603601	2
Variable Transformer Fuse, 10A (220V)	1603625	2
Variable Transformer Fuse, 20A (120V)	1603629	2
Panel Switch, 31-121- Momentary, 1 Pole	1860120	1
Led 24V White	1420163	3
Led 24V Red	1420162	1
Led 24V Green	1420161	1

SECTION 13: RETURNED MATERIAL

If for any reason it should become necessary to return this equipment to the factory, the Service Department of Phenix Technologies, Inc. must be given the following information:

Name Plate Information
Model Number
Serial Number
Reason for Return
Cause of Defect

If Phenix Technologies, Inc. deems return of the part appropriate; it will then issue an "Authorization for Return". If return is not deemed advisable, other inspection arrangements will be made. NOTE: Material received at this plant without the proper authorization shall be held as "Customer's Property" with no service until such time as the proper steps have been taken.

Your cooperation is requested in order to ensure prompt service.

