



User's Guide

MRM10E

Digital Micro-Ohmmeter



GU-1522
Copyright © Phenix Technologies. All rights reserved.

Rev 6/22/2018

MRM10E

WARNING !!

DANGER

Complete Grounding of this unit is necessary for the safe operation of this equipment. Disconnect inputs before ungrounding this equipment.

SAFETY PRECAUTIONS

- This equipment should be operated only by qualified and trained personnel, closely observing the corresponding safety regulations and instructions contained in the User guide.
- Check that the item to be measured is voltage free.
- Before starting with the measurements, be sure that the battery is well charged and that the line voltage is between specified limits.
- DO NOT connect or disconnect the test leads during the measurement.
- There are no adjustable parts or parts that can be replaced by the user within the equipment. Taking out the Control Panel to have access to the internal parts is dangerous as there are high voltages inside
- capable of causing fatal accidents.
- Cleaning of this instrument should be carried out using a soft cloth and cleaning liquid, after verifying that it doesn't attack the plastic parts used in the case and in the Control Panel of this equipment.

This equipment should be used only by a trained and competent person, strictly applying suitable safety rules.

Used symbols



	Caution, refer to User Guide.
	Equipment complies with current EU Directives.
	The rubbish bin with a line through it means that in the European Union, the product must undergo selective disposal for the recycling of electric and electronic material, in compliance with Directive WEEE 2002/96/EC.

Table of Contents

1. Description	5
1.1. Operating principle	5
2. Control panel	6
3. Power supply	7
3.1. Battery condition	7
3.2. Battery charger	7
4. Measurement	8
5. Messages	9
6. Some notes about accuracy	9
7. RS232 output	10
8. Cleaning	10
9. Replacement fuse	10
10. Technical specifications	11

1. Description

The **MRM-10E** micro-ohmmeter is a portable, microprocessor-controlled instrument, used to accurately measure very low contact resistances of breakers and switches, busbars, transformers, and engine windings, etc, with test currents from 1mA to 10A.

- Kelvin architecture (four-terminal method).
- Digital reading, alphanumeric display.
- Up to 4½ digits readings.
- Powered by rechargeable battery or mains supply.
- 0.1 $\mu\Omega$ resolution.
- 200 Ω maximum reading.

1.1. Operating Principle

This device uses the Kelvin Bridge architecture, with four terminals, avoiding testing leads resistance to cause error during measurement. The operator may choose test current and the reading is obtained by comparison through internal high-stability standards. The result appears in the alphanumeric display that is very easy to read.

2. Control Panel

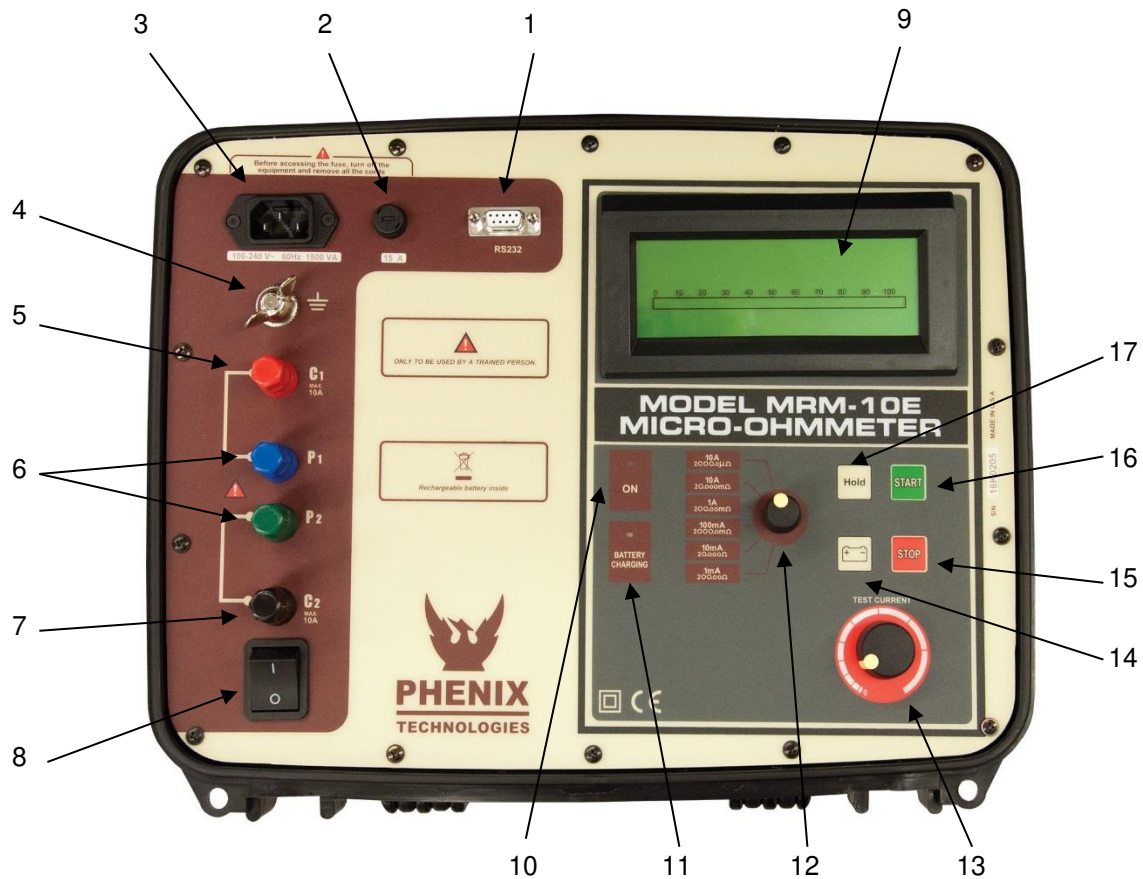

- | | |
|--|---|
| 1. RS-232 Data Output | 13. Test Current Control |
| 2. Fuse | 14. Battery Key (measures battery charge condition) |
| 3. Power Cord Connector | 15. STOP Key |
| 4. Ground | 16. START Key |
| 5. Current Terminal (C+) | 17. Hold Key (retains last measurement in display) |
| 6. Potential Terminals (P+ / P-) | |
| 7. Current Terminal (C-) | |
| 8. ON / OFF Switch | |
| 9. Displays both measured resistance value & messages for operator | |
| 10. ON Indicator LED | |
| 11. Battery Charge Indicator | |
| 12. Range & Test Current Selector | |

MRM10E

3. Power Supply

Mains supply or internal battery powered

Battery: rechargeable, 12 V – 7 Ah.

Mains: 220 – 240 V~ 50 Hz

At the end of the useful life, the battery must be recycled or disposed of properly to protect the environment.

3.1. Battery Condition

The charge condition of the battery can be verified before or during the resistance measurement. To achieve that, the operator has to press the **battery** key while the equipment is turned on. The bar graph shows remaining charge as a percentile value. If during measurement the charge of the battery achieves a critical level, the display will show the **BAT** message notifying that the charge level is low. After a few minutes the measurement will be automatically interrupted to preserve the battery from a deep discharge that is prejudicial for its expected useful life.

3.2. Battery Charger

The built-in battery charger is always active when the equipment is connected to the mains supply, even if the **On/Off** switch is turned off.

Charging Procedure:

- Check that the **On/Off** switch is in Off position.
- Connect the equipment to the mains supply.
- The **battery charge indicator** will keep on lighting with a red light up to completing the charge. At that point, it will change to a green light, and remain until the equipment is disconnected from the mains supply.

4. Measurement

CAUTION: Check that the item to be measured is voltage free.

1. Before turning the equipment On, connect the test leads to the item to be measured and to the front panel terminals.

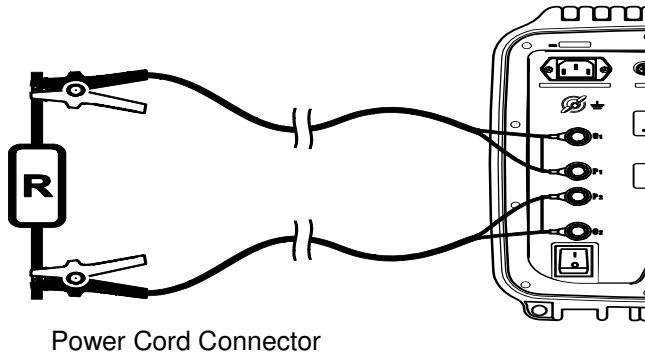

(The alligator clamps in the drawing are only for illustration.)

2. Using the **test current selector**, choose the range and the current to be used.
3. Choose the power supply to use. If you are going to use the battery, advance to the following point. If you are going to use the mains supply, plug the power cord into the **connector**.
4. Switch the equipment On using the **On/Off** switch.
5. The *PRESS START* message will appear showing that measurement can be started. Press the **Start** key. Depending on the position of the **test current control**, the *LOW CURRENT* message will turn up.
6. Turning the **test current control** clockwise increases the current. Adjust this control until obtaining the desired value or until the current indicator (bar graph) indicates 100%. The bar graph will show the test current value as a percentage of the nominal value selected by using the **test current selector**.
7. The lowest current for measuring is 10% of the nominal value. It is important to consider that the measurement errors increase while test current decreases. The equipment accuracy is specified for test currents higher than 80%.
8. The **display** will show the resistance value measured and the corresponding unit (Ω [ohms], $m\Omega$ [milli-ohms] or $\mu\Omega$ [micro-ohms]).
9. The value can be retained in the display by pressing the **hold** key. Pressing this key again, the value will be released.
10. Press the **Stop** key to finish the measurement. Do not turn Off the equipment without pressing the **Stop** key.
11. Finally, when finishing measurements, turn the equipment Off using the **On/Off** switch.

CAUTION: Do not connect or disconnect the test leads during the measurement.

5. Messages

MRM-10E

When turning the equipment On using the **On/Off** switch, this introductory message appears briefly. During that time, the equipment carries out functional checking.

WAIT...

This message appears each time the equipment needs to adjust any parameter to optimize the readings.

PRESS START

The equipment is ready to start a measurement, thus the operator has to press the **Start** key.

LOW CURRENT

It shows that the test current is not enough to carry out the reading. It appears at the beginning of each test and it keeps on being there up to the operator rotates the **test current control** clockwise, as necessary for the test current to be higher than 10 % of the nominal current in the scale. The inappropriate connection of the cables may cause a difficult circulation of test current. If this message keeps on being displayed, please check that the current cables are connected appropriately.

OVERRANGE

It indicates that the measured resistance is higher than the maximum value readable in the selected range.

H

Indicates that the value is the one retained in the memory when pressing the **hold** key.

BAT

It shows that the battery is discharged. It is necessary to recharge the battery.

6. Some Notes About Accuracy

To obtain the specified accuracy, the operator has to adjust the test current to a value higher than the 80% of the nominal value. If it is necessary, it is possible to use a lower current, but by doing this the accuracy will be affected.

MRM-10E has an auto-compensation system that automatically eliminates the error produced by internal offset. Thus, it is not necessary to carry out measurements by reversing the polarity to compute the average value. Nevertheless, if the operator suspects that there is a difference of temperature between the contact points that may generate thermoelectric voltages, it is necessary to carry out two measurements by reversing the current cables and so, the circulation sense of the current through the resistance under measurement. The resistance value to be measured will be the average between the values in one sense and in the contrary (direct and inverse current).

7. RS-232 Output

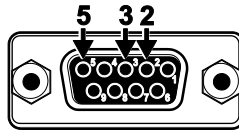

The **RS-232** data port on the control panel can be used to register measurements in a serial printer or data collector. The outputs are the following ones:

Pin 2: Rx ; Pin 3: Tx ; Pin 5: Gnd;
Rate: 4800 bps
8 bits - no parity - 1 stop bit (8,n,1)

Note: To assure the compatibility with most printers available in the market, the resistance units are shown with the following symbols:

uR = micro-ohm
mR = milli-ohm
R = ohm

8. Cleaning

CAUTION: Before cleaning, ensure that the unit is Off and removed from power connection.

The panel, terminals, and connectors of the equipment must stay dry and clean. Clean using a damp cloth in water and a soft detergent or isopropyl alcohol (be sure that the products to be used for cleaning do not affect plastic goods).

9. Replacement Fuse

To check the instrument **fuse**, remove it with a screw driver. If the fuse is ruptured, replace it by another with the following specifications:

Fuse Schurter, model SPT 5x20 (Time-lag) 5A/250V. High breaking capacity.

10. Technical Specifications

Test currents	: 1 mA – 10 mA – 100 mA – 1 A – 10 A . Each current may be continuously adjustable from 0 to 100%.
Resistance ranges	: 0 – 2000 $\mu\Omega$ @ 10 A 0 – 20 m Ω @ 10 A 0 – 200 m Ω @ 1 A 0 – 2000 m Ω @ 100 mA 0 - 20 Ω @ 10 mA 0 - 200 Ω @ 1 mA
Resolution	: 0.1 $\mu\Omega$ @ 10 A
Output voltage	: Up to 10 Vdc. @ 1 A (open circuit).
Measurement principle	: Four-terminal, Kelvin-type.
Basic accuracy	: $\pm(0.10\%$ of reading + 0.005 % full scale)
Advanced features	: Digital direct reading of very low resistances in the alphanumeric display, with up to 4½ digits. Very fast and accurate measurements.
Serial data output	: RS-232 @ 4800 bps. Suitable for data collection in an external serial printer, computer or data-logger.
Environmental protection	: IP54 with closed lid.
Safety class	: Meets the requirements of IEC 61010-1
Power supply	: Rechargeable battery 12 V – 7 Ah or 220-240 V~ 50 Hz mains supply.
Built-in battery charger	: 220-240 V~ 50 Hz mains supply.
Operating temperature range	: -5 C to 50 C / 23 F to 122 F
Storage temperature range	: -25 C to 65 C / -13 F to 140 F
Humidity range	: 95% RH (non condensing)
Weight	: Approx. 8.8 kg / 20 lbs.
Dimensions	: 378 x 308 x 175 mm / 15 x 12 x 7 inches
Accessories	: 2 Combined current and potential leads (1.8 m). 1 Ground cable. 1 Communication cable (RS-232). 1 Power cord. 1 User guide. 1 Carrying bag.

Subject to technical change without notice.

