

AC Resonant Test Systems – Tank Type

Up to 150 kV



Testing Applications

AC Resonant Test Systems are used where the load is largely capacitive with very low real power losses such as power cables, gas insulated switchgear, generator windings, and dry tests of insulator strings.

- **Steel grounded "dead"** tank design is **potential free**
- Can operate in both **parallel** and **series** resonant **modes**
- Extended **tuning range** available via **multiple output voltage taps**



Specifications are subject to change without notice.

Brochure No. **80102**

AC Resonant Test Systems

Phenix Technologies has supplied AC Resonant Test Systems and AC Dielectric Test Systems for over 40 years. As a worldwide leader in high voltage, high current, and high power testing applications, we have earned a reputation for producing high quality test systems and exceeding our customers' expectations. Phenix Technologies is ISO 9001:2008 compliant which ensures high quality standards are met through each step of the design and manufacturing process to give our customers a superior product with years of service. Our test systems function in compliance with IEC 60060-1, IEEE 4, and other recognized national and international industry testing standards.

Phenix Technologies produces several configurations of variable voltage, variable inductance AC Resonant Test Systems and offers options for additional testing capabilities. AC Resonant Test Systems measure dielectric performance of electrical equipment and insulating materials at all voltage levels. Additionally, these test systems are ideally suited to be paired with partial discharge measurement equipment and tangent delta (power factor) bridges. Phenix AC Resonant Test Systems are built for indoor or fair weather outdoor operation, but optionally may be designed to operate in adverse outdoor conditions.

Quality Construction Ensures Reliability

In addition to our quality standards, we conduct final pre-shipment tests at our facility where your representative can be present. Testing and operator training are available at this time or later once the test system is on-site. Supervision of on-site set-up, commissioning, and final operator training are available as options. Phenix Technologies' test systems are designed and built to provide years of reliable service. Rigorous factory testing before shipment ensures that the units function properly. Our standard tests include:

- Control and functionality test
- Ratio and polarity test (if equipped with exciter transformer)
- Resistance measurement
- Short circuit impedance test (if equipped with exciter transformer)
- No-load test
- Load test*
- Traceable meter calibration
- 110% overvoltage test at 2 minutes
- Flashover test
- Partial discharge test

* Heat Run Test and Full Load Tests are available for most systems; please check with your Phenix Sales Representative for further details.

Resonance Theory and Q

A resonant circuit consists of both capacitance (load) and inductance (test set). Resonance is defined as the condition that occurs when net inductive reactance equals the net capacitive reactance. Resonance is achieved when the energy absorbed at any instant is exactly equal to that released by another reactive element in the system. When the system has reached a state of resonance, it requires no further reactive power because it is self-sustaining. Only the real losses which primarily consist of $I^2 \cdot R$ winding losses and reactor core losses have to be supplied by the excitation winding.

When an R-L-C circuit is excited at its frequency, it may be characterized by the ratio of reactive power flow in the circuit to the real power input required to sustain stable (constant voltage) resonance. This ratio is known as the Quality Factor, or simply "Q", of the circuit. From general resonance theory, the Quality Factor is directly proportional to the maximum energy stored in the reactive elements of the circuit divided by the total energy lost per alternating voltage cycle. In a high voltage test circuit, the "Q" may be straightforwardly viewed as the ratio of Output Reactive Power [KVAR] to Input Real Power [kW]. Therefore in a high voltage resonant test circuit where $Q = 100$, the input power required by the test set is only approx. 1/100 (or 1%) of the reactive power required by the test object. This huge reduction in input power is the reason why resonant test systems are used almost exclusively when performing AC voltage tests on test objects having large capacitances.

Parallel or Series Resonant Mode

Choosing to operate in Parallel or Series mode depends upon the test object and the measurements to be conducted. A **series** resonant mode is best suited for sensitive partial discharge requirements that include some cables, HV transformers, bushings, and gas-insulated switchgear. Harmonics from the supply are better suppressed than in parallel mode.

The **parallel** resonant mode provides a more stable output voltage with test objects such as large generator windings or other specimens with corona losses. In parallel mode, the rate of rise is stable independent of the degree of tuning or Q of the circuit. Parallel mode also allows the test set to be energized to full voltage without a load. This is used to calibrate instrumentation and to check the partial discharge of the test equipment.

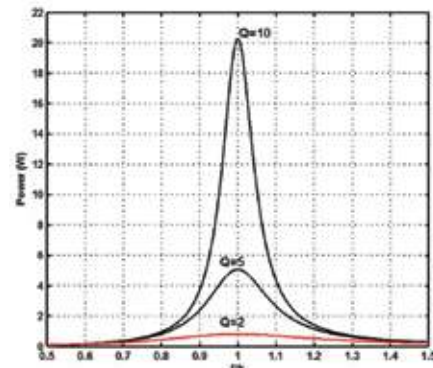

Advantages

Resonant Test Systems have several major advantages over conventional AC dielectric test sets including:

- Reduced input power requirements that save costs in installation and service
- Because the circuit utilizes a tuned circuit at the power frequency, a pure sine wave, without harmonics or distortion, appears across the test sample
- No power follow-up is required as a result of test failure
- When partial discharge measurements are required, the reduced input kVA requirements result in proportionately less expensive line filter systems
- Test equipment is reduced in both size and weight over conventional AC dielectric test sets

TANK TYPE Resonant Test Systems

- Can be electrically connected in parallel or series resonant mode
- Can be built with several output voltage taps to extend the tuning range
- May have the bushing installed in either vertical or angled configuration depending upon application

Safety and Design Features

Phenix Technologies designs in numerous safety features to protect personnel and equipment from potential injury, loss, or damage. To protect against flashovers or short circuits, our units have an adjustable electronic overload circuit. The circuit has a response time of less than 30 milli-seconds. The test systems have an input circuit breaker and backup overload protection. Additional safety features are included in our automated control software. All test sets include the following standard protection features:

- Main power circuit breaker
- Emergency stop switch with key lock
- Zero-start interlock
- Slow and fast acting overload protection
- Overvoltage and overcurrent controls
- External safety interlock provisions
- External warning circuit connections
- Overload circuit adjustable from 10% to 110% of rated current; includes indicator with reset

System Components

All Resonant Test Systems contain 5 main components: High Voltage Reactor, Power Regulator, Exciter Winding Transformer, High Voltage Divider, Controls.

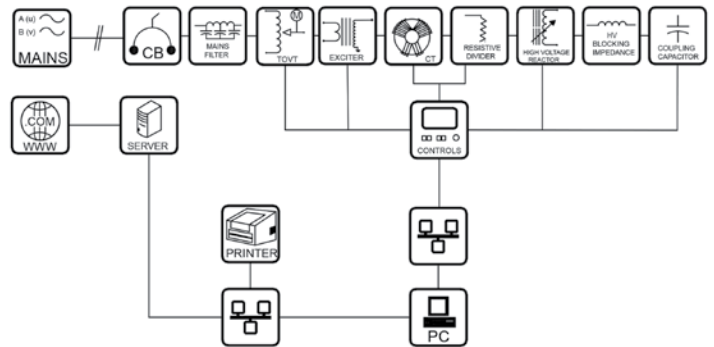

High Voltage Reactor

Enclosed in a rugged steel tank, the variable core, oil-insulated reactor is adjusted until its inductive reactance is equal to the capacitive reactance of the test specimen. The copper windings are of layer type construction. The coils are mounted to the fixed part of the core to surround the two variable gaps. The vertical core uses a gear reducer and ball screw arrangement with heavy vertical supports to create a rigid structure with few moving parts. This design results in a considerable reduction in size and weight.

- Reactor core and coils are contained in an oil filled tank
- Motorized drive system is used to vary the air gap
- Designed to minimize inter-element capacitance
- Built to withstand harsh forces from severe flashover
- Over-temperature protection
- Minimal mechanical vibration reduces audible noise



HV Tank Type Reactors <150 kV

(Sizes and weights shown are approximate for standard designs and may vary with custom orders)

Output kV	Power kVA	Duty Cycle	Design Frequency Hz	Length Inches (mm)	Width Inches (mm)	Height Inches (mm)	Weight lbs (kg)
22	288	½ Hr ON / 4 Hr OFF	50	38 (970)	41 (1053)	41 (1053)	2500 (1134)
27/19.8/16	900	5 Min ON / 30 Min OFF	60	88 (2235)	55 (1385)	72 (1820)	6900 (3130)
35	310	5 Min ON / 15 Min OFF	50	36 (927)	36 (927)	52 (1310)	1700 (771)
35	400	5 Min ON / 15 Min OFF	60	36 (927)	64 (1625)	69 (1753)	5200 (2359)
36	300	1 Hr ON / 1 Hr OFF	50	36 (927)	52 (1310)	56 (1422)	6300 (2858)
40	1000	5 Min ON / 15 Min OFF	60	82 (2083)	52 (1310)	81 (2057)	7800 (3538)
40	1250	Continuous	50	98 (2489)	73 (1854)	106 (2692)	11200 (5080)
45	500	5 Min ON / 15 Min OFF	60	37 (940)	48 (1220)	48 (1220)	2850 (1293)
50	125	1 Hr ON / 1 Hr OFF	50	36 (927)	36 (927)	77 (1956)	2500 (1134)
50/40/25	500	5 Min ON / 15 Min OFF	60	49 (1250)	40 (1016)	54 (1360)	2750 (1247)
50/30	600	1 Hr ON / 1 Hr OFF	50	86 (2184)	62 (1575)	64 (1625)	7400 (3357)
50	1000	5 Min ON / 15 Min OFF	50	47 (1200)	82 (2083)	72 (1820)	5860 (2658)
50/25	1250	5 Min ON / 15 Min OFF	50	90 (2286)	65 (1651)	82 (2083)	10000 (4536)
60	600	Continuous	60	82 (2083)	68 (1727)	82 (2083)	8200 (3720)
60/30	900	30 Min ON / 60 Min OFF	50	83 (2120)	60 (1524)	80 (2030)	11000 (4990)
60/30	1000	5 Min ON / 15 Min OFF	60	70 (1780)	53 (1346)	94 (2388)	8000 (3629)
60/40/20	1200	1 Hr ON / 1 Hr OFF	50	118 (2997)	64 (1625)	90 (2286)	14200 (6441)
60/45	2100	1 Hr ON / 1 Hr OFF	60	128 (3251)	86 (2184)	118 (2997)	17000 (7711)
60	3800	5 Min ON / 15 Min OFF	60	86 (2184)	67 (1701)	97 (2464)	15400 (6985)
70	1400	1 Hr ON / 1 Hr OFF	60	83 (2120)	75 (1905)	80 (2032)	9600 (4355)
75/50/25	750	1 Hr ON / 1 Hr OFF	60	96 (2438)	73 (1854)	83 (2120)	11000 (4990)
75/50/35	1500	15 Min ON / 15 Min OFF	60	99 (2515)	116 (2946)	98 (2489)	13750 (6237)
75/35	2250	1 Hr ON / 1 Hr OFF	50	108 (2743)	86 (2184)	93 (2362)	16500 (7484)
75/50/25	12160	1 Hr ON / 1 Hr OFF	50	132 (3353)	118 (2997)	138 (3505)	47000 (21319)
90/60/30	1250	1 Hr ON / 1 Hr OFF	50	103 (2616)	89 (2261)	105 (2667)	1700 (771)
100/50/35	500	1 Hr ON / 1 Hr OFF	60	102 (2600)	54 (1360)	76 (1930)	7100 (3221)
100/75/50	1000	1 Hr ON / 1 Hr OFF	50	102 (2600)	78 (1981)	82 (2083)	11000 (4990)
100/50	1000	1 Hr ON / 1 Hr OFF	60	96 (2438)	73 (1854)	82 (2083)	10400 (4717)
100/50/25	1500	1 Hr ON / 1 Hr OFF	50	111 (2819)	74 (1880)	93 (2362)	15500 (7031)
100/80/55	1500	1 Hr ON / 1 Hr OFF	50	122 (3099)	97 (2464)	93 (2362)	17500 (7938)
100/50	10000	1 Hr ON / 1 Hr OFF	60	148 (3759)	89 (2261)	130 (3302)	34700 (15740)
150/120/65/35	750	5 Min ON / 15 Min OFF	60	151 (3835)	71 (1803)	100 (2540)	15300 (6940)
150/100/40	2000	1 Hr ON / 1 Hr OFF	60	150 (3810)	93 (2362)	93 (2362)	21500 (9752)
150/92/80/37	3000	1 Hr ON / 1 Hr OFF	60	157 (3988)	85 (2159)	110 (2794)	25000 (11340)

Design Frequency

Units are typically optimized for one operating frequency

- 50 Hz unit may be operated at 60 Hz with a 20% reduction in tuning range
- 60 Hz units may be operated at 50 Hz with a 20% output voltage reduction



Power Regulator

The regulator provides an adjustable input voltage to the exciter and controls the output voltage of the high voltage reactor from near zero to full voltage. The power regulator is designed and manufactured by Phenix Technologies and consists of variable auto transformers of either toroidal or column type construction depending upon the power rating of the unit.

- Housed in a rugged steel cabinet with provisions for moving by fork lift
- Forced air cooling with air filters
- Removable panels for easy service and maintenance
- System controls may be contained within the regulator cabinet or in a separate console

Exciter Transformer

The exciter section consists of a two-winding, single-phase transformer that supplies the power to the resonant circuit. The exciter steps up the output voltage level to the reactor.

- Located electrically between regulator and HV reactor
- Motorized high voltage switches for selecting taps
- Rugged, oil-filled enclosure
- Built with double-shielded isolation screen
- Contains lower voltage output taps that ease tuning to high Q loads

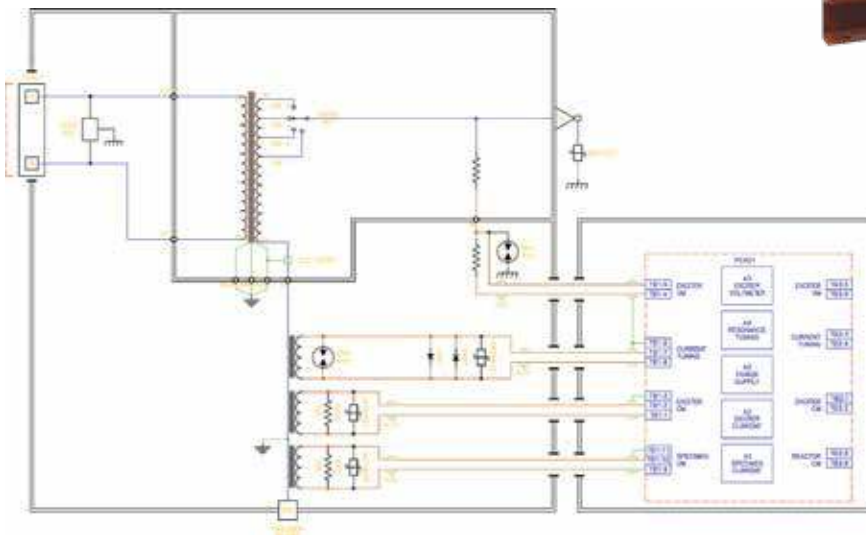
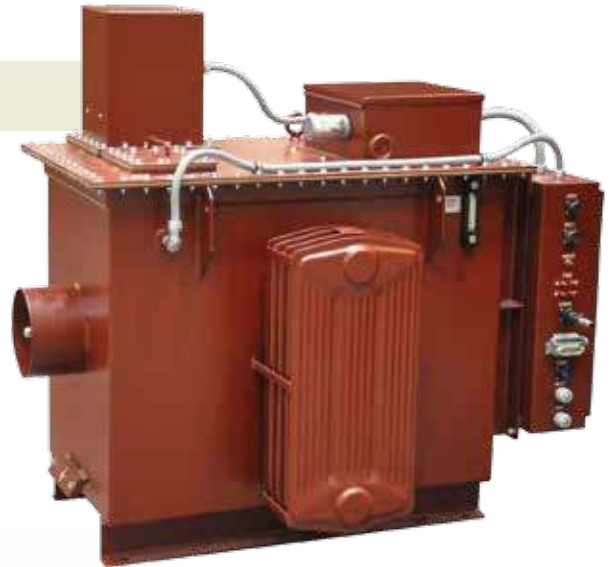

Controls

Phenix offers two types of operating control packages for our Resonant Test Systems:

800D Series Controls

The 800D Series is a basic control and metering solution and includes the following:

- Emergency Off pushbutton switch
- Control Power On indicator
- Security Circuit with indicator for use with test cage interlock system
- Zero-start interlock, which requires operator to raise voltage from zero level
- High Voltage On/Off pushbuttons with indicator
- Motorized control of output voltage from near zero to full voltage with Raise/Lower pushbuttons and end of travel indicator
- Auto tuning switch with indicator
- Pushbuttons for changing reactance when tuning to resonance in manual mode
- Electronic arc detector and overload circuit with indicator and reset pushbutton
- Automatic return of motorized regulator to zero position when high voltage is shut off or when a failure occurs
- Reactor over temperature protection
- Provision for external warning device (maximum 250 VA)
- Primary overload protection with reset switch and indicator
- Gap position indicator
- Tap switch with position sensing indicator (optional)

The control panel is hinged for easy access to the relays and electronics inside.



800D Series Instrumentation

Output Voltmeter, single range, digital, peak-responding calibrated to peak volts $/\sqrt{2}$, accuracy $\pm 0.8\%$ of reading $\pm 0.2\%$ of range

Exciter Voltmeter, single range, digital, accuracy $\pm 2\%$ FS

Output Currentmeter, single range, digital, RMS-reading, operator may select to read exciter or specimen current, accuracy $\pm 2\% \pm \text{LSD}$ (least significant digit)

Resonant meter, zero-center null meter to indicate resonance point



Skid Mounted System



800C Series Controls

The 800C series represent the latest development in computer-assisted controls. Our configuration creates ease in set-up and simplicity in testing. The test system features an industrial-grade color touch screen Human Machine Interface (HMI) and Ethernet port for automated control of your tests via a Personal Computer. Functions and metering included on the HMI display:

- Auto Ranging Output Voltmeter
- Auto Ranging Specimen Currentmeter
- Auto Ranging Excitation Voltage and Current Meters
- Meters include Bar Graphs that indicate percent of full scale
- Peak Memory Output Voltmeter (records maximum voltage applied to test specimen)
- Fault Memory Output Voltmeter (records voltage at which the specimen failed)
- Resonance Indicator (null type indicator for tuning the resonant circuit)
- Precise Automatic Tuning and Voltage Control (can also be manually controlled via touch screen)
- Dwell Timer (time elapsed while at test voltage level)
- Duration Timer (total test time for multi-level Automatic Sequence Tests)
- User Programmable Dwell Time and Test Voltage Level (Automatic Voltage Test)
- User Programmable Automatic Sequence Test
- Up to ten Test Profiles can be stored in the HMI (virtually unlimited number of profiles in a PC via Ethernet)
- User Programmable Over Voltage Set Point (turns voltage off immediately if level is reached)
- Message display that indicates system status and fault information
- Regulator and Reactor Gap Controls (motorized drives)
- Exciter and Reactor Tap Selectors (optional motorized high voltage tap switches)
- Variable Inductance (gap drive) and Voltage Regulator Speed Control

Also included are calibration and service modes. All adjustments needed for yearly recalibration are simply made by adjusting a few numbers in the software via the Human Machine Interface. The service mode assists and simplifies maintenance, and helps in the diagnosis of failed components in the rare cases that may be necessary.

800C Series Instrumentation

A high precision measuring system is designed to enable accurate measurement of voltages and currents. The metered information is displayed on the Human Machine Interface (HMI) display. The values displayed on the HMI are performed as a function of the Programmable Logic Controller (PLC). The following metering measurements are displayed:

Output Voltage is measured by means of peak responding circuitry and is displayed in its peak/ 2 value. Accuracy \pm (0.8% of reading + 0.2% of range to least significant digit (LSD))

Specimen Current is measured by means of true RMS conversion. Accuracy \pm (0.8% of reading + 0.2% of range to LSD)

Exciter Voltage is measured by means of peak responding circuitry and is displayed in its peak/ 2 value. Accuracy \pm 1% of Full Scale

Exciter Current is measured by means of true RMS conversion. Accuracy \pm (0.8% of reading + 0.2% of range to LSD)

Resonance is measured and displayed as a zero-center null type bar graph indicator

Duration and Dwell Timers. Time is displayed in an HOURS:MINUTES:SECONDS format from 0000:00:00 to 9999:59:59.

Peak Voltage Memory Meter. The maximum applied test voltage level is retained and displayed.

Fault Voltage Memory Meter. The applied test voltage level at the time of a specimen failure is retained and displayed.

Specialty test applications may be accommodated by options within our designs. Please consult one of Phenix Technologies Sales Representatives for further information.

Software

Phenix Technologies PC based software provides innovative features through a user friendly interface. The operator enters specific test parameters, or recalls previous test "recipes" for easy test duplication. Test results can be displayed, stored to a database, or printed.

Test Results

Test results can be viewed in table or chart format and show real-time voltages, current, step, dwell, and duration data. Report generating options allow for a concise or detailed print-out of data.

Test History

The software collects all saved test results in a database for easy recall and review. Search, sort, and printing of previous test results can be performed.

Test Profiles

Create new test profiles or "recipes" by selecting a custom test, cycle test, or step test and then choosing a tap value. A screen opens to enter test criteria desired, and the test profile is saved, and may be run or downloaded. Quickly recall previous profiles by test type, description, or ID value.

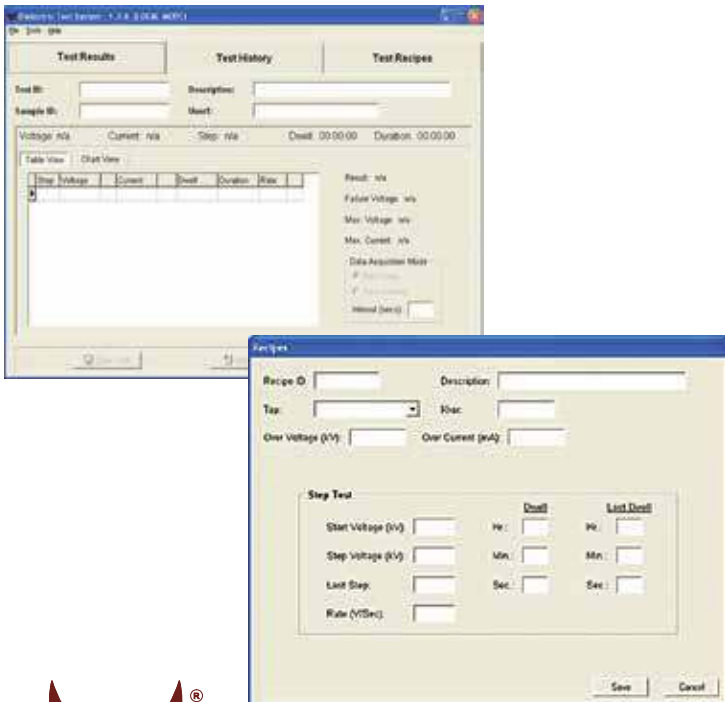

**PHENIX
TECHNOLOGIES**

WORLD HEADQUARTERS

Phenix Technologies, Inc.
75 Speicher Drive
Accident, MD 21520 USA
Ph: +1.301.746.8118
Fx: +1.301.895.5570
Info@phenixtech.com

BRANCH OFFICES

Phenix Systems AG
Riehenstrasse 62A, 4058 Basel, Switzerland
Ph: +41.61.383.2770, Fx: +41.61.383.2771, Info@phenixsystems.com

Phenix Asia
Zhong Cheng Rd, Sec 1, No 177, 2F, Taipei 11148 Taiwan
Ph: +886.2.2835.9738, Fx: +886.2.2835.9879, Info@phenixasia.com

Cables

Phenix Technologies supplies interconnect cables 20 feet (6 m) from the High Voltage Reactor to the Exciter Transformer and from the Power Regulator to the Exciter Transformer. Power input cabling from mains and the cables required to the test specimen are the customer's responsibility.

Options

- Control Desk
- Casters and/or skid mounting for easier movement of larger system components
- Line Filters to reduce mains interference
- High Voltage Filters for sensitive PD measurements
- PD Detectors
- Tangent Delta Bridges
- Extended cable lengths
- On-site Training
- On-site Service and Calibration
- ISO 17025 Calibration

Warranty and After Sales Service

Phenix Technologies designs and builds AC Resonant Test Systems to provide years of efficient and dependable service. A long term warranty is included with every system. On-site periodic maintenance and calibration contracts, or extended warranties are available as options.

Phenix Technologies' Service Department is ready to assist our customers by answering inquiries or by dispatching technicians if serious issues arise. Our worldwide facilities provide locations that stock some critical parts or may offer assistance in troubleshooting if required. Commonly used spare parts are available from our factory inventory in Maryland (USA), and can be shipped worldwide, expedited delivery if necessary. We stand behind our products and the Service Department is available to assist in gaining full value from your equipment.



ISO
9001:2008
Compliant